

TOOLS & EQUIPMENT

CATALOGUE

INDUSTRI

TOOLS & EQUIPMENT



'Let's Get To Work!'



A0029140

Metric Go/No Go Thread Ring Gauges			
System Code	Stock Code	Size	Pitch
Go Ring	No Go Ring	6g	mm
A0029140	NGRM3C	M3	0.5
A0029144	NGRM4C	M4	0.7
A0029146	NGRM5C	M5	0.8
A0029147	NGRM6C	M6	1.0
A0029149	NGRM8C	M8	1.25
A0029097	NGRM10C	M10	1.5
A0029102	NGRM12C	M12	1.75
A0029106	NGRM14C	M14	2.0
A0029112	NGRM16C	M16	2.0
A0029115	NGRM18C	M18	2.5
A0029120	NGRM20C	M20	2.5
A0029205	NGRM22C	M22	2.5
A0029125	NGRM24C	M24	3.0
A0029130	NGRM27C	M27	3.0
A0029131	NGRM30C	M30	3.5
A0029138	NGRM36C	M36	4.0
A0029141	NGRM42C	M42	4.5

BSP Go/No Go Thread Ring Gauges			
System Code	Stock Code	Size	TPI
Go Ring	No Go Ring	DIN 255	
A0029091	NGRBSP1/8C	1/8BSP	28
A0029090	NGRBSP1/4C	1/4BSP	19
A0029094	NGRBSP3/8C	3/8BSP	19
A0029089	NGRBSP1/2C	1/2BSP	14
A0029182	NGRBSP5/8C	5/8BSP	14
A0029093	NGRBSP3/4C	3/4BSP	14
A0029092	NGRBSP1C	1BSP	11

Fine Metric Go/No Go Thread Ring Gauges			
System Code	Stock Code	Size	Pitch
Go Ring	No Go Ring	6g	mm
A0029146	NGRM5x0.5C	M5	0.5
A0029147	NGRM6x0.5C	M6	0.5
A0029148	NGRM6x0.75C	M6	0.75
A0029149	NGRM8x0.75C	M8	0.75
A0029151	NGRM8x1C	M8	1.0
A0029098	NGRM10x.75C	M10	0.75
A0029100	NGRM10x1C	M10	1.0
A0029099	NGRM10x1.25C	M10	1.25
A0029105	NGRM12x1C	M12	1.0
A0029103	NGRM12x1.25C	M12	1.25
A0029104	NGRM12x1.5C	M12	1.5
A0029109	NGRM14x1C	M14	1.0
A0029108	NGRM14x1.5C	M14	1.5
A0029114	NGRM16x1C	M16	1.0
A0029113	NGRM16x1.5C	M16	1.5
A0029117	NGRM18x1C	M18	1.0
A0029116	NGRM18x1.5C	M18	1.5
A0029118	NGRM18x2C	M18	2.0
A0029122	NGRM20x1C	M20	1.0
A0029121	NGRM20x1.5C	M20	1.5
A0029123	NGRM22x1.5C	M22	1.5
A0029126	NGRM24x1.5C	M24	1.5
A0029127	NGRM24x2C	M24	2.0
A0029128	NGRM25x1.5C	M25	1.5
A0029129	NGRM26x1.5C	M26	1.5
A0029132	NGRM30x1.5C	M30	1.5

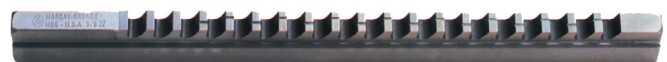

A0019340

HSS Push Type Keyway Broaches					
System Code	Size	Style	No of Shims	Min. Cut Length	Max. Cut Length
	mm				
A0019340	2	I	0	5.1	28
A0019341	3	I	1	5.1	28
A0019343	4	II	1	7.5	43
A0019344	5	II	1	7.5	43
A0019348	5	III	1	10.3	63
A0019349	6	III	1	10.3	63
A0019290	8	III	1	10.3	63
A0019352	10	IV	2	19	150
A0019291	12	IV	2	19	150
A0019292	14	IV	2	19	150
A0019361	16	V	3	19	150
A0019362	18	V	3	19	150
A0019364	20	VI	3	19	150
A0019365	22	VI	4	19	150
A0019366	24	VI	4	19	150
A0019367	25	VI	4	19	150

NOTE: Also available ex stock: Guide bushes, shims, Hex, square, corner square broaches, pull broaches and Imperial size broaches.



A0019358



COSBW200X2X32X220C

BW geometry, the teeth are alternatively beveled and is suitable for cutting round and square tube.

Sets of HSS Push Type Keyway Broaches		
System Code	Size	Bush Diameter
	mm	mm
A0019358	2 mm Style I 3 mm Style I	6, 7, 8, 9, 10
A0019359	2 mm Style I 3 mm Style I	8, 10
	4 mm Style II 5 mm Style II	12,14, 16, 18
	6 mm Style III 8 mm Style III	18, 19, 20, 22, 24, 25 26, 28, 30, 32, 34, 36

Sets of HSS Push Type Keyway Broaches		
System Code	Size	Bush Diameter
	mm	mm
A0019360	4 mm Style II 5 mm Style II 6 mm Style III 8 mm Style III	12,14, 16, 18 20, 22, 24, 26, 28

Sets of HSS Push Type Keyway Broaches		
System Code	Size	Bush Diameter
	mm	mm
A0019353	10 mm Style IV 12 mm Style IV 14 mm Style IV	34, 36, 38, 40 42, 44, 46, 48

Sets of HSS Push Type Keyway Broaches		
System Code	Size	Bush Diameter
	mm	mm
A0019357	16 mm Style V 18 mm Style V	54, 56, 58, 60, 62, 64

Sets of HSS Push Type Keyway Broaches		
System Code	Size	Bush Diameter
	mm	mm
KBSET14-18	14 mm Style IV 16 mm Style V 18 mm Style V	44, 45, 46, 48, 50 52, 54, 55, 56, 58, 60 62, 64, 65, 66, 68, 70

NOTE: Imperial size Keyway broach sets available ex stock

HSS Circular Blades for Cut Off Machines				
System Code	Ø	Width	Bore	No. of Teeth
	mm	mm	mm	
COSBW200X2X32X220C	200	2	32	220
COSBW200X2X32X160C	200	2	32	160
COSBW225X2X32X220C	225	2	32	220
COSBW225X2X32X200C	225	2	32	200
COSBW225X2X32X180C	225	2	32	180
COSBW250X2X32X220C	250	2	32	220
COSBW250X2X32X160C	250	2	32	160
COSBW250X2X40X280C	250	2	40	280
COSBW250X2X40X220C	250	2	40	220
COSBW250X2.5X40X240C	250	2.5	40	240
COSBW250X2.5X32X280C	250	2.5	32	280
COSBW250X2.5X32X240C	250	2.5	32	240
COSBW250X2.5X32X220C	250	2.5	32	220
COSBW250X2.5X32X160C	250	2.5	32	160
COSBW275X2X32X280C	275	2	32	280
COSBW275X2X40X280C	275	2	40	280
COSBW275X2.5X32X280C	275	2.5	32	280
COSBW275X2.5X32X220C	275	2.5	32	220
COSBW275X2.5X32X180C	275	2.5	32	180
COSBW275X2.5X40X280C	275	2.5	40	280
COSBW300X2X32X300C	300	2	32	300
COSBW300X2X32X280C	300	2	32	280
COSBW300X2X32X220C	300	2	32	220
COSBW300X2X40X280C	300	2	40	280
COSBW300X2X40X220C	300	2	40	220
COSBW300X2.5X32X220C	300	2.5	32	220
COSBW300X2.5X32X160C	300	2.5	32	160
COSBW300X2.5X32X120C	300	2.5	32	120
COSBW300X2.5X40X180C	300	2.5	40	180
COSBW315X2.5X32X280C	315	2.5	32	280
COSBW315X2.5X32X220C	315	2.5	32	220
COSBW315X2.5X40X280C	315	2.5	40	280
COSBW315X2.5X40X220C	315	2.5	40	220
COSBW315X2.5X40X180C	315	2.5	40	180
COSBW315X3X32X310C	315	3	32	310
COSBW315X3X32X220C	315	3	32	220
COSBW315X3X32X180C	315	3	32	180



HSS Circular Blades for Cut Off Machines				
System Code	Ø	Width	Bore	No. of Teeth
	mm	mm	mm	
COSBW315X3X40X310C	315	3	40	310
COSBW315X3X40X240C	315	3	40	240
COSBW315X3X40X180C	315	3	40	180
COSBW350X3X32X310C	350	3	32	310
COSBW350X3X32X220C	350	3	32	220
COSBW350X3X32X160C	350	3	32	160
COSBW400X3X40X310C	400	3	40	310

HSS Circular Blades for Cut Off Machines				
System Code	Ø	Width	Bore	No. of Teeth
	mm	mm	mm	
COSHZ315X2.5X32X280C	315	2.5	32	280
COSHZ315X2.5X32X220C	315	2.5	32	220
COSHZ315X2.5X32X180C	315	2.5	32	180
COSHZ315X2.5X40X280C	315	2.5	40	280
COSHZ315X2.5X40X220C	315	2.5	40	220
COSHZ315X2.5X40X180C	315	2.5	40	180
COSHZ315X3X32X220C	315	3	32	220
COSHZ350X3X32X310C	350	3	32	310
COSHZ350X3X32X220C	350	3	32	220
COSHZ350X3X32X160C	350	3	32	160
COSHZ350X3X40X220C	350	3	40	220
COSHZ350X3X40X180C	350	3	40	180



COSHZ200X2X32X220C



The HZ tooth form is used mainly for solid round and square bar as well as thick-walled tube cutting, the roughing tooth is beveled on both sides and between 0.2 And 0.3 Mm higher than the finishing tooth.

BW Geometry, the Teeth are Alternately Beveled and is Suitable for Cutting Round and Square Tube.



COSHZ200X2X32X220C



HSS Circular Blades for Cut off Machines				
System Code	Ø	Width	Bore	No. of Teeth
	mm	mm	mm	
COSHZ200X2X32X220C	200	2	32	220
COSHZ200X2X32X160C	200	2	32	160
COSHZ225X2X32X180C	225	2	32	180
COSHZ250X2X32X220C	250	2	32	220
COSHZ250X2X32X200C	250	2	32	200
COSHZ250X2X32X160C	250	2	32	160
COSHZ250X2X40X220C	250	2	40	220
COSHZ250X2.5X32X280C	250	2.5	32	280
COSHZ250X2.5X32X220C	250	2.5	32	220
COSHZ250X2.5X32X200C	250	2.5	32	200
COSHZ250X2.5X32X160C	250	2.5	32	160
COSHZ275X2X32X280C	275	2	32	280
COSHZ275X2X32X220C	275	2	32	220
COSHZ275X2X32X180C	275	2	32	180
COSHZ275X2X40X280C	275	2	40	280
COSHZ275X2X40X180C	275	2	40	180
COSHZ275X2.5X32X280C	275	2.5	32	280
COSHZ275X2.5X32X220C	275	2.5	32	220
COSHZ275X2.5X32X180C	275	2.5	32	180
COSHZ275X2.5X40X280C	275	2.5	40	280
COSHZ275X2.5X40X220C	275	2.5	40	220
COSHZ300X2X32X300C	300	2	32	300
COSHZ300X2X32X280C	300	2	32	280
COSHZ300X2X32X220C	300	2	32	220
COSHZ300X2X32X160C	300	2	32	160
COSHZ300X2X40X220C	300	2	40	220
COSHZ300X2.5X32X300C	300	2.5	32	300
COSHZ300X2.5X32X220C	300	2.5	32	220
COSHZ300X2.5X32X160C	300	2.5	32	160
COSHZ300X2.5X32X120C	300	2.5	32	120

Tin Coated HSS Cut Off Blades				
System Code	Ø	Width	Bore	No. of Teeth
	mm	mm	mm	
COSTIN200X2X32X160	200	2	32	160
COSTIN225X2X32X220	225	2	32	220
COSTIN225X2X32X160	002	2	32	180
COSTIN250X2X32X220	250	2	32	220
COSTIN250X2X32X160	250	2	32	160
COSTIN250X2X40X280	250	2	40	280
COSTIN250X2X40X220	250	2	40	220
COSTIN250X2.5X40X240	250	2.5	40	240
COSTIN250X2.5X32X280	250	2.5	40	280
COSTIN250X2.5X32X240	250	2.5	32	240
COSTIN250X2.5X40X220	250	2.5	32	220
COSTIN250X2.5X32X160	250	2.5	32	160
COSTIN275X2X32X280	275	2	32	280
COSTIN275X2X32X220	275	2	32	220
COSTIN275X2X32X180	275	2	32	180
COSTIN275X2X40X280	275	2	40	280
COSTIN275X2X40X180	275	2	40	180
COSTIN275X2.5X32X280	275	2.5	32	280
COSTIN275X2.5X32X220	275	2.5	32	220
COSTIN275X2.5X32X180	275	2.5	32	180
COSTIN275X2.5X40X280	275	2.5	40	280
COSTIN275X2.5X40X220	275	2.5	40	220
COSTIN300X2X32X300	300	2	32	300
COSTIN300X2X32X280	300	2	32	280
COSTIN300X2X32X220	300	2	32	220
COSTIN300X2X32X160	300	2	32	160
COSTIN300X2X40X220	300	2	40	220
COSTIN300X2.5X32X300	300	2.5	32	300
COSTIN300X2.5X32X160	300	2.5	32	160
COSTIN315X2.5X32X280	315	2.5	32	280
COSTIN315X2.5X32X220	315	2.5	32	220
COSTIN315X2.5X40X220	315	2.5	40	220
COS315X2.5X40X180	316	2.5	40	180
COSCB350X3X32X220C	350	3	32	220



ASB255X30X100

TCT Saw Blades for Aluminium				
System Code	Ø	Width	Bore	No. of Teeth
	mm	mm	mm	
ASB255X30X100	255	3.0	30	100
ASB255X30X120	255	3.0	30	120
ASB305X30X100	305	3.0	30	100
ASB305X30X120	305	3.0	30	120
ASB355X30X144	355	3.2	30	100
ASB400X30X120	400	3.4	30	120
ASB450X30X120	450	4.0	30	120
ASB500X30X120	500	4.4	30	120



SAW63x.3x16

HSS Fine Tooth Slitting Saws				
System Code	Ø	Width	Bore	No. of Teeth
	mm	mm	mm	
SAW63x.3x16	63	0.3	16	128
SAW63x.4x16	63	0.4	16	128
SAW63x.5x16	63	0.5	16	128
SAW63x.6x16	63	0.6	16	100
SAW63x.7x16	63	0.7	16	100
SAW63x.8x16	63	0.8	16	100
SAW63x.9x16	63	0.9	16	100
SAW63x1x16	63	1.0	16	100
SAW63x1.2x16	63	1.2	16	80
SAW63x1.5x16	63	1.5	16	80
SAW63x1.6x16	63	1.6	16	80
SAW63x2x16	63	2.0	16	80
SAW63x2.5x16	63	2.5	16	64
SAW63x3x16	63	3.0	16	64
SAW63x4x16	63	4.0	16	64
SAW63x5x16	63	5.0	16	48
SAW63x6x16	63	6.0	16	48
SAW80x.5x22	80	0.5	22	128
SAW80x.6x22	80	0.6	22	128
SAW80x.7x22	80	0.7	22	128
SAW80x.8x22	80	0.8	22	128
SAW80x.9x22	80	0.9	22	100
SAW80x1x22	80	1.0	22	100
SAW80x1.2x22	80	1.2	22	100
SAW80x1.5x22	80	1.5	22	100
SAW80x1.6x22	80	1.6	22	100
SAW80x2x22	80	2.0	22	80
SAW80x2.5x22	80	2.5	22	80
SAW80x3x22	80	3.0	22	80
SAW80x3.5x22	80	3.5	22	80
SAW80x4x22	80	4.0	22	64
SAW80x5x22	80	5.0	22	64
SAW100x.5x22	100	0.5	22	160
SAW100x.6x22	100	0.6	22	160

HSS Fine Tooth Slitting Saws				
System Code	Ø	Width	Bore	No. of Teeth
	mm	mm	mm	
SAW100x.8x22	100	0.8	22	128
SAW100x.9x22	100	0.9	22	128
SAW100x1x22	100	1.0	22	128
SAW100x1.2x22	100	1.2	22	128
A0025109	100	1.5	22	128
A0025087	100	1.6	22	100
A0025081	100	2.0	22	100
A0025080	100	2.5	22	100
A0025091	100	3.0	22	80
SAW100x3.5x22	100	3.5	22	80
A0025111	100	4.0	22	80
A0025112	100	5.0	22	80
A0025113	100	6.0	22	64
A0025092	125	1.2	27	128
A0025115	125	1.5	27	128
A0025093	125	1.6	27	128
A0025094	125	2.0	27	128
A0025069	125	2.5	27	100
A0025120	125	3.0	27	100
A0025121	125	4.0	27	100
A0025095	125	5.0	27	80
A0025123	125	6.0	27	80
A0025124	160	1.2	32	160
SAW160x1.6x32	160	1.6	32	160
SAW160x2x32	160	2.0	32	128
A0025125	160	2.5	32	128
A0025126	160	3.0	32	128
A0025070	160	4.0	32	100
A0025128	160	5.0	32	100
SAW160x6x32	160	6.0	32	100
SAW200x1x32	200	1.0	32	200
SAW200x1.5x32	200	1.5	32	200
A0025129	200	1.6	32	160
A0025130	200	2.0	32	160
SAW200x2.5x32	200	2.5	32	160
A0025131	200	3.0	32	128
SAW200x6x32	200	6.0	32	100
A0025084	250	2.0	32	200
SAW250x4x32	250	4.0	32	160
SAW315x3x40	315	3.0	40	200
SAW315x4x40	315	4.0	40	160



A0025096

HSS Coarse Tooth Slitting Saws				
System Code	Ø	Width	Bore	No. of Teeth
	mm	mm	mm	
A0025096	80	0.8	22	64
A0025098	80	1.0	22	40
A0025097	80	1.6	22	40
A0025100	80	2.0	22	40
A0025099	80	2.5	22	32
A0025101	80	3.0	22	32
A0025102	80	4.0	22	32

HSS Coarse Tooth Slitting Saws				
System Code	Ø	Width	Bore	No. of Teeth
	mm	mm	mm	
CSAW100x1x22	100	1.0	22	50
CSAW100x1.2x22	100	1.2	22	50
CSAW100x1.6x22	100	1.6	22	50
CSAW100x2x22	100	2.0	22	40
CSAW100x2.5x22	100	2.5	22	40
CSAW100x3x22	100	3.0	22	40
CSAW125x1.2x27	100	6.0	22	32
CSAW125x1.2x27	125	1.2	27	64
CSAW125x1.6x27	125	1.6	27	50



SF63x8x22

HSS Staggered Tooth Side & Face Cutters - Fine Tooth				
System Code	Ø	Width	Bore	No. of Teeth
	mm	mm	mm	
SFF100x8x22	±0.1	K11	H7	24
SFF100x10x22	100	8	22	24
SFF100x14x22	100	10	22	24
SFF100x16x27	100	14	22	24
SFF125x16x27	100	16	27	24
	125	16	27	26

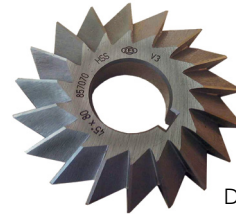

DA63 x 45

HSS Staggered Tooth Side and Face Cutters - Coarse Tooth				
System Code	Ø	Width	Bore	No. of Teeth
	mm	mm	mm	
SF63x8x22	±0.1	K11	H7	12
SF63x12x22	63	8	22	12
SF63x12x22	63	12	22	12
SF80x8x27	80	8	27	14
SF80x10x22	80	10	22	14
SF80x10x27	80	10	27	14
SF80x12x27	80	12	27	14
SF100x10x27	100	10	27	14
SF100x12x27	100	12	27	14
SF100x12x27	100	12	27	14
SF100x12x32	100	12	32	14
SF125x12x32	125	12	32	16



SFF50x4x16

HSS Double Equal Angle Cutters				
System Code	Ø	Width	Bore	Included Angle
	mm	mm	mm	
DA63 x 45	63	10	22	45°
DA80 x 45	80	12	27	45°
DA100 x 45	100	18	32	45°
DA63 x 60	63	14	22	60°
DA80 x 60	80	16	27	60°
DA100 x 60	100	22	32	60°
DA63 x 90	63	16	22	90°
DA80 x 90	80	20	27	90°
DA100 x 90	100	28	32	90°



SA63x45

HSS Single Angle Cutters				
System Code	Ø	Width	Bore	Included Angle
	mm	mm	mm	
SA63x45	12	22	63	45°
SA80x45	16	27	22	45°
SA100x45	22	32	80	45°
SA50x60	12	16	27	60°
SA63x60	16	22	100	60°
SA80x60	20	27	32	60°
SA100x60	25	32	50	60°

HSS Staggered Tooth Side & Face Cutters - Fine Tooth				
System Code	Ø	Width	Bore	No. of Teeth
	mm	mm	mm	
SFF50x4x16	±0.1	K11	H7	18
SFF50x5x16	50	4	16	18
SFF50x6x16	50	5	16	18
SFF50x6x16	50	6	16	18
SFF63x5x22	63	4	22	20
SFF63x6x22	63	5	22	20
SFF63x8x22	63	6	22	20
SFF63x10x22	63	8	22	20
SFF63x10x22	63	10	22	20
SFF80x6x22	80	4	22	22
SFF80x8x22	80	6	22	22
SFF80x10x22	80	8	22	22

HSS Involute Gear Milling Cutters

Form Relieved. 20° Pressure Angle. Basic Profile 1 to DIN 3972
(Depth = 2.167 x Module)



G0006936

* When Ordering Please Suffix System Code with Cutter Number.



HSS Involute Gear Milling Cutters Continued				
System Code	Module	Pressure Angle	Cutter	Bore
	mm		Ø	
G0006936	0.5	20°	28	13
M1*	1	20°	60	22
G0006937	1.25	20°	60	22
A0018788	1.5	20°	60	22
A0019821	1.75	20°	60	22
M2*	2	20°	60	22
A0019829	2.25	20°	60	22
A0018789	2.5	20°	60	22
A0019833	2.75	20°	70	27
M3*	3	20°	70	27
M3.25*	3.25	20°	70	27
A0019967	3.5	20°	80	27
A0019840	3.75	20°	80	27
M4*	4	20°	80	27
A0019843	4.5	20°	80	27
M5*	5	20°	90	32
M5.5*	5.5	20°	90	32
M6*	6	20°	100	32
M7*	7	20°	105	32
M8*	8	20°	105	32
M9*	9	20°	110	32
M10*	10	20°	120	32

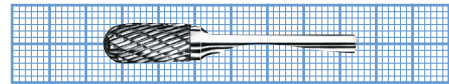

A0017173

Ball Nose Cylinder (ISO Shape C)			
System Code	Head Ø	Head Length	Shank Ø
	mm	mm	mm
A0017173	2	6	3
A0017174	3	12	3
C3x12x6	4	12	6
C6x12x3	6	12	3
A0017176	6	16	6
A0017150	8	20	6
A0017147	10	20	6
A0017148	12	25	6
A0017149	16	25	6

NOTE: Burrs with no Chip Breaker or Burrs with the Number of Teeth other Than Standard, Available on Request.

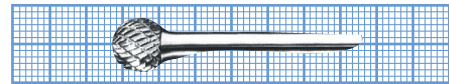

A0017152

Ball Nose Cylinder (ISO Shape D)		
System Code	Head Ø	Shank Ø
	mm	mm
A0017152	3	3
A0017153	6	3
A0017154	6	6
A0017155	8	6
A0017177	10	6
A0017178	12	6
A0017151	16	6

Supplied as Standard with Super Cut Chip Breaker. Cylinder. ISO shape A

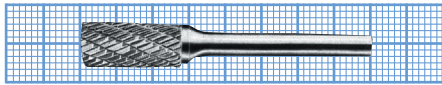

A0017167

Solid Carbide Rotary Burrs			
System Code	Head Ø	Head Length	Shank Ø
	mm	mm	mm
A0017167	2	6	3
A0017168	3	12	3
A3x12x6	3	12	6
A4x14x6	4	14	6
A0017169	6	12	3
A0017170	6	16	6
A0017171	8	20	6
A0017138	10	20	6
A12x6x6	12	6	6
A0017139	12	25	6
A0017140	16	25	6

NOTE: Burrs with no chip breaker or burrs with the number of teeth other than standard, available on request.

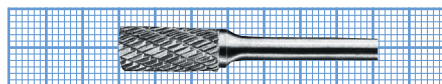

A0017144

End Cutting Cylinder. ISO Shape B			
System Code	Head Ø	Head Length	Shank Ø
	mm	mm	mm
A0017144	3	12	3
A0017145	4	14	6
A0017146	6	16	6
A0017172	8	20	6
A0017141	10	20	6
B12x6x6	12	6	6
A0017142	12	25	6
A0017143	16	25	6

NOTE: Burrs with no chip breaker or burrs with the number of teeth other than standard, available on request.

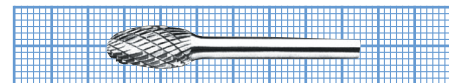

A0017179

Oval Nose Cylinder (ISO Shape E)			
System Code	Head Ø	Head Length	Shank Ø
	mm	mm	mm
A0017179	3	6	3
A0017180	6	10	6
A0017156	10	16	6
A0017157	12	22	6
A0017158	16	25	6

NOTE: burrs with no chip breaker or burrs with the number of teeth other than standard, available on request.

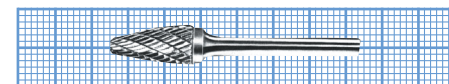

A0017182

Ball Nose TreeCylinder (ISO Shape F)			
System Code	Head Ø	Head Length	Shank Ø
	mm	mm	mm
A0017182	3	12	3
A0017183	6	12	3
A0017184	6	16	6
A0017181	10	20	6
A0017159	12	25	6
A0017160	16	25	6

NOTE: Burrs with no chip breaker or burrs with the number of teeth other than standard, available on request.

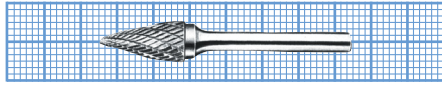

G3x12x3

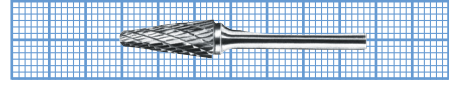

A0017192

Ball Nose Tree Cylinder (ISO Shape G)

System Code	Head Ø	Head Length	Shank Ø
	mm	mm	mm
G3x12x3	3	12	3
A0017187	3	12	6
G6x12x3	6	12	3
A0017162	6	16	6
A0017188	8	20	6
A0017185	10	20	6
A0017186	12	25	6
A0017161	16	25	6

NOTE: Burrs with no chip breaker or burrs with the number of teeth other than standard, available on request.

Ball Nose Cone (ISO Shape L)

System Code	Head Ø	Head Length	Shank Ø
	mm	mm	mm
A0017192	3	12	3
A0017193	6	16	6
A0017190	10	30	6
A0017191	12	30	6
A0017164	16	30	6

NOTE: Burrs with no chip breaker or burrs with the number of teeth other than standard, available on request.

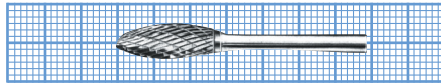

A0017189

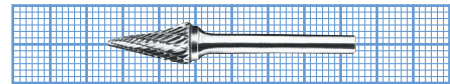

A0017166

Ball Nose Flame Cylinders (ISO Shape H)

System Code	Head Ø	Head Length	Shank Ø
	mm	mm	mm
A0017189	8	20	6
A0017163	12	30	6

NOTE: Burrs with no chip breaker or burrs with the number of teeth other than standard, available on request.

Ball Nose Cone Cylinders (ISO Shape M)

System Code	Head Ø	Head Length	Shank Ø
	mm	mm	mm
A0017166	3	12	3
A0017195	3	16	3
A0017196	3	16	6
A0017197	6	16	6
A0017194	10	20	6
A0017165	12	25	6

NOTE: Burrs with no chip breaker or burrs with the number of teeth other than standard, available on request.

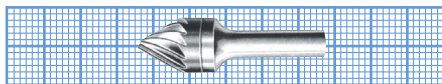

A0020722



N6x6x3

60° Countersink (ISO Shape J)

System Code	Head Ø	Head Length	Shank Ø	Included Angle
	mm	mm	mm	
A0020722	10	10	6	60°
A0020723	12	12	6	60°
A0020724	16	16	6	60°

NOTE: Supplied Without Chipbreaker.

Inverted Cone Cylinders (ISO Shape N)

System Code	Head Ø	Head Length	Shank Ø
	mm	mm	mm
N6x6x3	6	6	3
A0017199	6	6	6
A0017198	12	12	6

NOTE: Burrs with no chip breaker or burrs with the number of teeth other than standard, available on request.

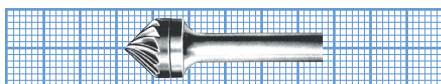

A0020725

90° Countersink Cylinders (ISO Shape K)

System Code	Head Ø	Head Length	Shank Ø	Included Angle
	mm	mm	mm	
A0020725	10	8	6	90°
A0020726	12	10	6	90°
A0020727	16	12	6	90°

NOTE: supplied without chipbreaker.

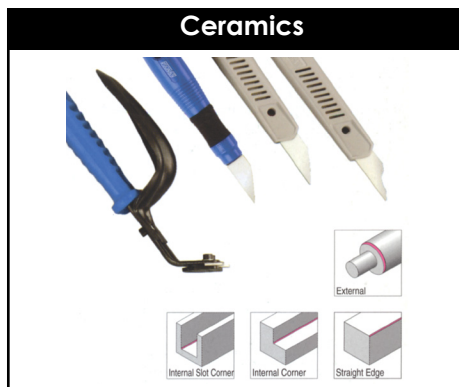
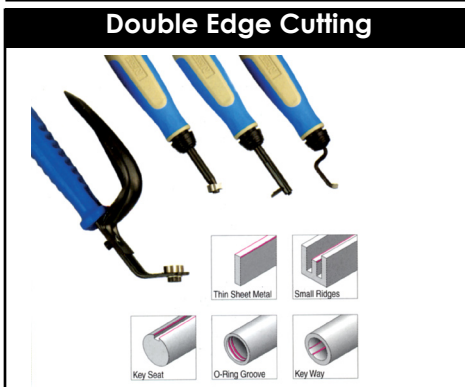
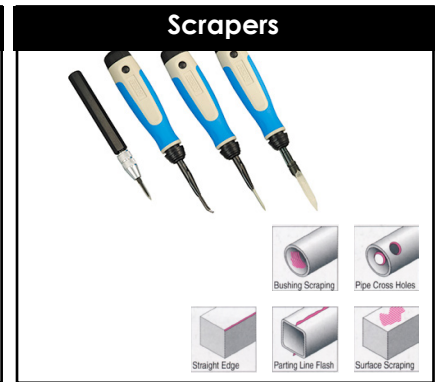
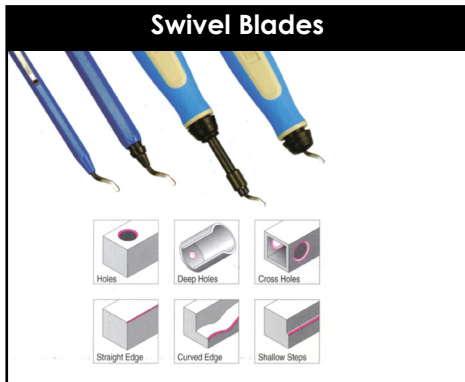

NG Handle



A0018968 Holds all 'S' Blades with large's



G0009444 With 3 Blades - S10, S20, S35



G0009445 With 5 Blades - S10, S20, S35, S101, S202



A0018970 Holds all Blade Holders



A0018971 NG3000 handle, S Holder, S20, S30, S100 Blades

S Holder



A0018967 Blade Holder. Telescopes from 0-115 mm. Holds all 'S' Blades.

N Holder



A0019033 Holds Light Duty 2.6 mm Blades. Telescopes from 25-115 mm. Holds all "N" Blades

C Holder



A0019034 Holds C12, C20, C30 Countersink Heads

Edge Off



A0019035 Edge off Disposable Tool



A0019052 Fine mini scraper for internal scraping
Blade A0018986



A0019051 Chamfer the OD on bars and tubes
range 8-28 mm



A0018987 Fine internal scraper for deburring
bottom side of holes Blade



A0018966 Double burr for sheet metal.



A0019035 Disposable burr tool. With S10
blade

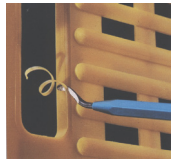

A0018974 Rapid burr aluminium handle
with S10 blade

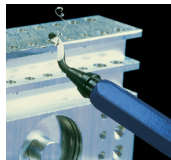

NG3300 Keyway deburring tool.



A0019053 Leader burr. external
chamfering tool.



Blade A0019028 - Soft 65°
A0019029 - Hard 75°



NC5100 Handle with ceramic blade for soft abrasive plastic.
NC5200 Handle with ceramic blade for hard abrasive plastic.
NC5000 Handle only



A0018972 Countersink with 20 mm \varnothing
countersink.



BLADE : A0019019
SC1500 Heavy-duty adjustable scraper
Blade 7.4 mm x 120 mm



A0018969 Roto-drive countersink.
Cranked bit holder with 10.4 mm \varnothing
countersink. The quickest way to chamfer
by hand



BLADE : A0019020
SC8000 Adjustable Scraper



Blade 4.2 mm x 80 mm



A0019050 Roto-drive countersink
Cranked bit holder with 20 mm \varnothing
countersink. The quickest way to chamfer by hand

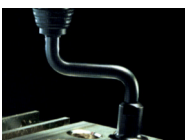

A0019059 Range 3-5.5 mm \varnothing
A0019060 Range 5-9 mm \varnothing
A0019061 Range 10-22 mm \varnothing

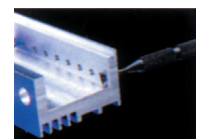

Countersinking / Reverse Countersinking

Plastic Body Type Reamer

For Aluminium, Brass and Copper Tubing

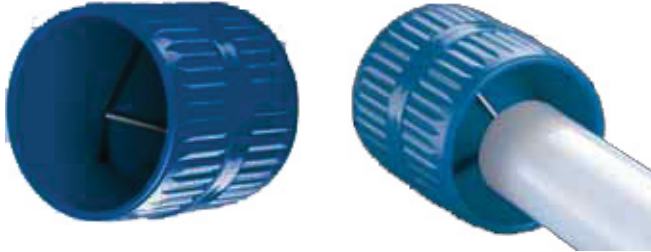

System Code	Range	Blades
A0019065	4-42 mm	3

Deburring System Swivel Blades Regular Size Blades Type "S" Heavy- Duty

- A0014478  Heavy-Duty. For Steel, Aluminium and plastic.
- A0019014  PVD coated tin for high wear materials.
- A0019016  Heavy-Duty for Brass and Cast Iron.
- A0019017  Simultaneously removes external and internal burrs.
- A0018965  For straight edges.
- A0019018  For deburring the inside of cross holes and back side of walls.







Regular Size Blades - Type K

- A001898  Fine point blade for small holes, for Steel, plastic and Aluminium.
- A001898  PVD coated Tin
- A001899  Fine point blade with heavy-duty shank for Brass and cast iron.

Small Size Blades - Light Duty Type N

- A0018995  For Steel, plastic and Aluminium.
- A0018996  PVD coated Tin for high wear materials
- A0018999  For brass and Cast Iron.
- A0019001  Simultaneously removes external and internal burrs.





Cranked Blades

- A0018983  Patented cranked countersink 3.2 mm for small holes 0-3 mm
- A0018984  Patented cranked countersink 6.3 mm
- A0018985  Patented cranked countersink 8.3 mm
- A0018978  Patented cranked countersink 10.4 mm
- A0018980  Patented cranked countersink 16.5 mm
- A0019036  Patented cranked external countersink

Fixed Blades

- A0019004  Blades used with double-burr.
- A0019005  M42-Co for stainless steel.
- A0019003  For keyways 1.2-8 mm.
- A0019008  For keyways 3-15 mm.
- A0018993  Blade used with leader for steel and aluminium.
- A0018979  12 mm countersink, fits into c-holder
- A0018981  20 mm countersink, fits into c-holder
- A0018982  30 mm countersink, fits into c-holder

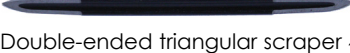
Scraper Blades

-  Internal mini scraper 3 mm
- A0018987  Internal scraper blade 3.2 mm
- BD8001  Double-ended triangular scraper 4.2 mm
- A00190109  Double-ended triangular scraper 7.4 mm



Platinum Boxes

A0019058



Meets the total requirements of tool and die makers and deburring specialists

Includes: Double Burr, NogaGrip 1 Handle, NogaGrip 3 Handle, Teddy Burr Handle, S Holder, N Holder, D Holder & D50, D Holder & D66, K Holder & N80K, C Holder & C20 Countersink, T Holder & T70, 18 mm external RotoDrive Blade, 10.4 mm Countersink RotoDrive.
Swivel Blades: N1, N2, S10, S20, S30, S150, 1.5 mm Hex Key.

Bronze Unikits

A0019055



The most economical deburring kit for all machinists.

Includes: NogaGrip 3 Handle, S holder, N Holder, C Holder & C20, D Holder & D50.
Swivel Blades: N1, N2, S10, S20, S30, S150.

Gold Boxes

A0019057



The most complete box for professional machinists.

Includes: NogaGrip 3 Handle, Adjustable Scraper, Plastic Edge-Off Handle, S Holder, N Holder, D Holder & D50, K Holder & N80K, C Holder & C20.
Swivel Blades: N1, N2, S10, S20, S30, S150, D66, 10.4 mm Countersink RotoDrive, 1.5 mm Hex Key.

The Sets

A0018975



The 7 most popular tools.

Includes: NG3003 Handle and S Blades, NG 3100 Countersink, NG3300 Keyway, NG3710 Internal Scraper, NG3200 V-cut, NG3700 Mini Scraper and SC 8000 adjustable scraper.

Silver Boxes

A0019056



The most suitable for MRO.

Includes: NogaGrip 3 Handle, S Holder, Medium Reversible Countersink, Plastic Edge Off Handle, 3.2 mm RotoDrive Countersink, 10.4 mm RotoDrive Countersink, 16.5 mm RotoDrive Countersink, 18 mm External RotoDrive.
Swivel Blades: S10, S20, S30



PSB300X25X1.25

Power Hacksaw Blades				
System Code of Pack	Length	Height	TPI	Unit
	mm	mm		
PSB300X25X1.25	300	25	10,14	10
PSB350X25X1.25	350	25	10,14	10
PSB350X32X 1.60	350	32	6,10,14	10
PSB350X38X2.00	350	38	4,6	10
PSB400X25X1.25	400	25	10,14	10
PSB400X32X1.60	400	32	6,10,14	10
PSB400X38X2.00	400	38	4,6,10	10
PSB425X25X1.25	425	25	10,14	10
PSB425X32X1.60	425	32	6,10	10
PSB450X32X1.60	450	32	4,6,10,14	10
PSB450X38X2.00	450	38	4,6,10	10
PSB500X32X1.60	500	32	10	10
PSB500X40X2.00	500	40	4,6	10
PSB500X50X2.5	500	50	4,6	10
PSB525X40X2.00	525	40	4,6,10	5
PSB550X40X2.00	550	40	4,6	5
PSB600X50X2.50	600	50	4,6	5
PSB650X50X2.50	650	50	4,6	5
PSB700X50X2.5	700	50	4,6	5

Hacksaw Blades

Carbon Steel

High Carbon Steel blades for all light-duty work. Unbreakable in normal conditions. They are suitable for relatively soft materials such as aluminium, copper, brass, mild steel and other metals.

Bimetal M2

Bimetal, high speed steel hand hacksaw blades are virtually unbreakable bimetal blades for superb cutting performance. They cut through all types of materials including alloys and stainless steels.

Bimetal 8% Cobalt

A shatter proof blade for high wear resistance as compared to conventional bimetal blades. The teeth have a hardness of 66 to 68 HRC with a high wear resistance property. They cut through all types of materials including high alloy steels.



HSBF32

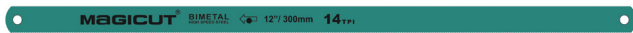

HSBBM18Q

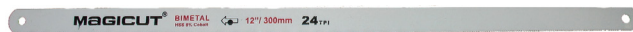

HSBBM24

Hacksaw Blades			
System Code	Length	Height	TPI
	mm	mm	mm
Carbon Steel			
A0027907	300	13	18
A0027908	300	13	24
HSBF32	300	13	32
Bi-Metal M2			
A0027904	300	13	18
A0027905	300	13	24
A0027906	300	13	32
Bi-Metal 8% Cobalt			
HSBBM18Q	300	13	18
HSBBM24Q	300	13	24
HSBBM32Q	300	13	32
Junior Hacksaw Blades			
HSB15018	150	13	18
A0027905	150	13	24



RTB4x63C

Round Toolbits (HSS)			Round Toolbits (HSS)		
System Code	Ø	Length	System Code	Ø	Length
	mm	mm		mm	mm
	j9	±2		j9	±2
A0018879	4	63	RTB10x63C	10	63
A0018880	4	80	A0018861	10	80
A0018878	4	100	A0018824	10	100
RTB5x63C	5	63	A0018860	10	160
A0018882	5	80	A0018825	10	200
A0018881	5	100	A0018862	12	100
A0018884	6	63	A0018863	12	160
RTB6x80C	6	80	RTB12x200C	12	200
A0018829	6	100	RTB16x100C	12	100
A0018883	6	160	RTB16x160C	14	160
A0018888	8	63	A0018828	14	200
A0018889	8	80	A0018871	16	160
A0018830	8	100	A0018872	16	200
A0018886	8	160	A0018876	20	200
A0018887	8	200			

10% Cobalts		
System Code	Ø	Length
	mm	mm
	jg	±2
RTBC0104x63C	4	63
RTBC0104x80C	4	80
RTBC0104x100C	4	100
RTBC0105x63C	5	63
RTBC0105x75C	5	75
RTBC0105x100C	5	100
RTBC0106x63C	6	63
RTBC0106x75C	6	75
RTBC0106x80C	6	80
RTBC0106x100C	6	100
RTBC0106x160C	6	160
RTBC0108x80C	8	80
RTBC0108x100C	8	100
RTBC0108x150C	8	150
RTBC0108x160C	8	160
RTBC0108x200C	8	200

10% Cobalts		
System Code	Ø	Length
	mm	mm
	jg	±2
RTBC01010x80C	10	80
RTBC01010x100C	10	100
RTBC01010x150C	10	150
RTBC01010x160C	10	160
RTBC01010x200C	10	200
RTBC01012x100C	12	100
RTBC01012x150C	12	150
RTBC01012x160C	12	160
RTBC01012x200C	12	200
RTBC01014x150C	14	150
RTBC01014x200C	14	200
RTBC01016x100C	16	100
RTBC01016x200C	16	200
RTBC01020x200C	20	200
RTBC01025x200C	25	200

V = Surface Speed m/min

n = RPM

D = Cutter Diameter

To calculate surface speed:

To calculate RPM:

$$V = \frac{\pi \cdot D \cdot n}{1000}$$

$$n = \frac{V \cdot 1000}{\pi \cdot D}$$

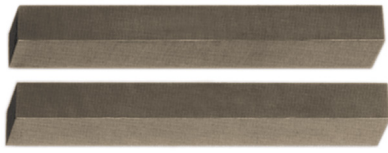

A0018843

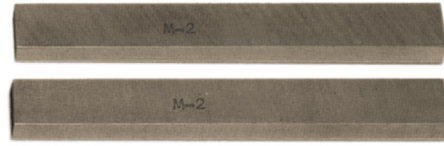

RTB8x4x100C

Square Toolbits (HSS)		
System Code	A/F	Length
	mm	mm
	h12	±2
A0018843	4	63
A0018842	4	100
A0018901	5	63
A0018902	5	80
A0000986	5	100
A0018904	6	63
STB6x80C	6	80
STB6x100C	6	100
STB6x160C	6	160
STB6x200C	6	200
STB8x63C	8	63
STB8x80C	8	80
STB8x100C	8	100
STB8x160C	8	160
STB8x200C	8	200
STB10x63C	10	63
STB10x80C	10	80

Square Toolbits (HSS)		
System Code	A/F	Length
	mm	mm
	h12	±2
STB10x100C	10	100
STB10x160C	10	160
STB10x200C	10	200
STB12x63C	12	63
STB12x80C	12	80
STB12x100C	12	100
STB12x160C	12	160
STB12x200C	12	200
STB14x200C	14	200
STB16x100C	16	100
STB16x160C	16	160
STB16x200C	16	200
STB18x200C	18	200
STB20x160C	20	160
STB20x200C	20	200
STB25x200C	25	200

Rectangular Toolbits (HSS)			
System Code	Height	Width	Length
	mm	mm	mm
	h12	h12	±2
RTB8x4x100C	8	4	100
RTB8x5x100C	8	5	100
RTB10x5x100C	10	5	100
RTB10x6x160C	10	6	160
RTB10x6x200C	10	6	200
RTB12x6x160C	12	6	160
RTB12x6x200C	12	6	200
RTB12x8x200C	12	8	200
RTB16x8x160C	16	8	160
RTB16x8x200C	16	8	200
RTB16x10x200C	16	10	200
RTB20x10x200C	20	10	200
RTB20x12x200C	20	12	200
RTB25x12x200C	25	12	200
RTB25x16x200C	25	16	200

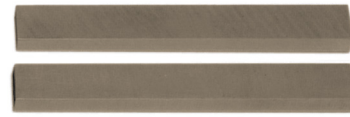

RTBCO1010x3x150C

5% Cobalts		
System Code	A/F	Length
	mm	mm
	h12	±2
STBC054x63C	4	63
STBC055x63C	5	63
STBC056x63C	6	63
STBC056x80C	6	80
STBC056x100C	6	100
STBC056x160C	6	160
STBC056x200C	6	200
STBC058x63C	8	63
STBC058x80C	8	80
STBC058x100C	8	100
STBC058x160C	8	160
STBC058x200C	8	200
STBC0510x63C	10	63
STBC0510x80C	10	80

5% Cobalts		
System Code	A/F	Length
	mm	mm
	h12	±2
STBC0510x100	10	63
STBC0510x160	10	63
STBC0510x200	10	63
STBC0512x63	12	80
STBC0512x80	12	100
STBC0512x100	12	160
STBC0512x160	12	200
STBC0512x200	12	63
STBC0516x100	16	80
STBC0516x160	16	100
STBC0516x200	16	160
STBC0520x160	20	200
STBC0520x200	20	63
STBC0525x200	25	80

10% Cobalts			
System Code	Height	Width	Length
	mm	mm	mm
	h12	h12	±2
RTBCO1010x3x150C	10	3	150
RTBCO1010x4x150C	10	4	150
RTBCO1010x4x200C	10	4	200
RTBCO1010x5x200C	10	5	200
RTBCO1010x6x150C	10	6	150
RTBCO1010x6x160C	10	6	160
RTBCO1010x6x200C	10	6	200
RTBCO1012x3x150C	12	3	150
RTBCO1012x4x150C	12	4	150
RTBCO1012x5x150C	12	5	150
RTBCO1012x5x200C	12	5	200
RTBCO1012x6x160C	12	6	160
RTBCO1012x6x200C	12	6	200
RTBCO1012x8x160C	12	8	160
RTBCO1012x8x200C	12	8	200
RTBCO1015x3x150C	15	3	150
RTBCO1015x4x150C	15	4	150
RTBCO1015x6x150C	15	6	150
RTBCO1015x6x200C	15	6	200
RTBCO1015x8x200C	15	8	200
RTBCO1015x10x200C	15	10	200
RTBCO1016x8x160C	16	8	160
RTBCO1016x10x160C	16	10	160
RTBCO1018x4x200C	18	4	200
RTBCO1020x3x200C	20	3	200
RTBCO1020x4x200C	20	4	200
RTBCO1020x6x160C	20	6	160
RTBCO1020x6x200C	20	6	200
RTBCO1020x8x160C	20	8	160
RTBCO1020x10x150C	20	10	150
RTBCO1020x10x160C	20	10	160
RTBCO1020x10x200C	20	10	200
RTBCO1020x12x200C	20	12	200
RTBCO1025x6x160C	25	6	160
RTBCO1025x8x200C	25	8	200
RTBCO1025x10x200C	25	10	200
RTBCO1025x16x200C	25	16	200
RTBCO1025x16x250C	25	16	250

10% Cobalts		
System Code	A/F	Length
	mm	mm
	h12	±2
STBC0104x63C	4	63
STBC0105x63C	5	63
STBC0106x63C	6	63
STBC0106x80C	6	80
STBC0106x100C	6	100
STBC0106x160C	6	160
STBC0106x200C	6	200
STBC0108x63C	8	63
STBC0108x80C	8	80
STBC0108x100C	8	100
STBC0108x160C	8	160
STBC0108x200C	8	200
STBC01010x63C	10	63
STBC01010x80C	10	80
STBC01010x100C	10	100

10% Cobalts		
System Code	A/F	Length
	mm	mm
	h12	±2
STBC01010x160C	10	160
STBC01010x200C	10	200
STBC01012x63C	12	63
STBC01012x100C	12	100
STBC01012x160C	12	160
STBC01012x200C	12	200
STBC01014x150C	14	150
STBC01014x200C	14	200
STBC01016x100C	16	100
STBC01016x160C	16	160
STBC01016x200C	16	200
STBC01018x200C	18	200
STBC01020x160C	20	160
STBC01020x200C	20	200
STBC01025x200C	25	200



A0027910

Parting Tool Blades HSS			
System Code	Height	Width	Length
	mm	mm	mm
A0027910	12	2.5	100
A0027911	16	3	130
A0027912	20	4	150
A0027913	25	4	150

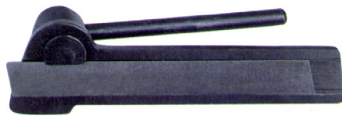

A0019071

Parting Tool Holders			
System Code	Blade Size	Width	Height
	mm	mm	mm
A0019071	12x2.5	8	19
A0019072	16x3	9.5	22
A0019073	20x4	13	28
A0019071	25x4	19	40

Supplied without Blades



A0018795

Turning Tool Holders - Straight Pattern				
System Code	Width	Height	Length	Toolbit
	mm	mm	mm	mm
A0018795	8	19	110	5
A0018796	10	22	125	6
H0001619	12	28	150	8
A0018793	16	33	175	9.5
A0018794	19	40	200	12

Supplied without toolbits
Left and right hand holders are available while stocks last.



G0000389

Boring Bars					
System Code	Toolbit	Bar Ø	Bar Length	Holder Size	Holder Length
	mm	mm	mm	mm	mm
G0000389	3	9.5	110	13	56
H0001621	5	11	130	13	63
A0031970	6	14	170	16	75
H0001618	8	19	230	22	95
H0001616	10	22	290	32	110
H0001620	12	30	350	40	125

Supplied without toolbits.



A0027410

Fly Cutters	
System Code	Description
A0027410	12.7 mm Shank 19, 29, 38 Diameter
A0027411	50 Diameter - 19 shank 8 mm Toolbit
A0027409	62 Diameter - R8 shank 8 mm toolbit



H0001560



Brazed Turning Tools - 75° Approach Straight Turning (Tool E)						
System Code	Designation mm	Shank Height	Shank Width	Direction	Grade	Used to Cut
		mm	mm			
H0001560	ISO1	10	10	RH	P25	Steel
A0018754	ISO1	12	12	RH	P25	Steel
A0018755	ISO1	16	16	RH	P25	Steel
H0001566	ISO1	20	20	RH	P25	Steel
H0001566	ISO1	25	25	RH	P25	Steel
H0001559	ISO1	10	10	LH	P25	Steel
H0001561	ISO1	12	12	LH	P25	Steel
H0001563	ISO1	16	16	LH	P25	Steel
A0001177	ISO1	20	20	LH	P25	Steel
A0001178	ISO1	25	25	LH	P25	Steel

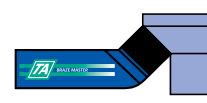

A0018770

Brazed Turning Tools - 45° Approach Cranked Turning (Tool J)						
System Code	Designation	Shank Height	Shank Width	Direction	Grade	Used to Cut
		mm	mm			
A0018770	ISO2	10	10	RH	P25	Steel
A0018771	ISO2	12	12	RH	P25	Steel
A0018772	ISO2	16	16	RH	P25	Steel
A0018773	ISO2	20	20	RH	P25	Steel
A0018775	ISO2	25	25	RH	P25	Steel
A0018769	ISO2	10	10	LH	P25	Steel
H0001597	ISO2	12	12	LH	P25	Steel
H0001601	ISO2	16	16	LH	P25	Steel
H0001604	ISO2	20	20	LH	P25	Steel
A0018774	ISO2	25	25	LH	P25	Steel
H0001595	ISO2	10	10	RH	K20	Cast Iron
H0001599	ISO2	12	12	RH	K20	Cast Iron
H0001603	ISO2	16	16	RH	K20	Cast Iron
H0001607	ISO2	20	20	RH	K20	Cast Iron
H0001609	ISO2	25	25	RH	K20	Cast Iron

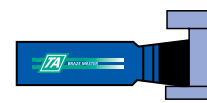

A0020695

Brazed Turning Tools - Recessing (Tool D)						
System Code	Designation	Shank Height	Shank Width	Direction	Grade	Used to Cut
		mm	mm			
A0020695	ISO4	10	10	RH	P25	Steel
A0018751	ISO4	12	12	RH	P25	Steel
A0018752	ISO4	16	16	RH	P25	Steel
A0018753	ISO4	20	20	RH	P25	Steel
A0020700	ISO4	25	25	RH	P25	Steel

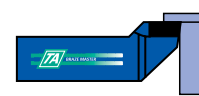

A0018740

Cranked Knife (Tool B)						
System Code	Designation	Shank Height	Shank Width	Direction	Grade	Used to Cut
		mm	mm			
A0018740	ISO6	10	10	RH	P25	Steel
A0018744	ISO6	12	12	RH	P25	Steel
A0018745	ISO6	16	16	RH	P25	Steel
A0018747	ISO6	20	20	RH	P25	Steel
A0019069	ISO6	25	25	RH	P25	Steel

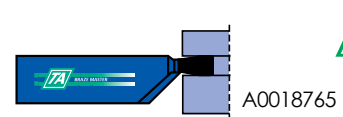
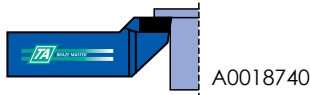

Cranked Knife (Tool B)						
System Code	Designation	Shank Height	Shank Width	Direction	Grade	Used to Cut
		mm	mm			
A0018740	ISO6	10	10	LH	P25	Steel
A0018742	ISO6	12	12	LH	P25	Steel
A0020672	ISO6	16	16	LH	P25	Steel
A0018746	ISO6	20	20	LH	P25	Steel
A0020683	ISO6	25	25	LH	P25	Steel
A0018739	ISO6	10	10	RH	K20	Cast Iron
A0018743	ISO6	12	12	RH	K20	Cast Iron
A0020675	ISO6	16	16	RH	K20	Cast Iron
A0020681	ISO6	20	20	RH	K20	Cast Iron
A0019068	ISO6	25	25	RH	K20	Cast Iron

Parting (Tool H)					
System Code	Designation	Shank Height	Shank Width	Direction	Used to Cut
		mm	mm		
A0018765	ISO7	12	12	RH	Steel
A0018766	ISO7	16	16	RH	Steel
A0018768	ISO7	20	20	RH	steel
A0018767	ISO7	12	12	RH	Steel
H0001592	ISO7	16	16	RH	Steel
H0001582	ISO7	12	12	RH	Cast Iron
H5RK20	ISO7	16	16	RH	Cast Iron
H6RK20	ISO7	20	20	RH	Cast Iron
H0001587	ISO7	20	12	RH	Cast Iron
H0001591	ISO7	16	16	RH	Cast Iron



Straight Knife (Tool G)					
System Code	Shank Height	Shank Width	Direction	Grade	Used to Cut
	mm	mm			
A0018761	10	10	RH	P25	Steel
A0018763	12	12	RH	P25	Steel
A0018764	16	16	RH	P25	Steel
H0001578	20	20	RH	P25	Steel
G8RP25	25	25	RH	P25	Steel
A0018760	10	10	RH	P25	Steel
A0018762	12	12	RH	P25	Steel
H0001575	16	16	RH	P25	Steel
H0001577	20	20	RH	P25	Steel
H0001579	25	25	RH	P25	Steel

Internal Boring Bar (P)						
System Code	Designation	Shank Height	Shank Width	Direction	Grade	Used to Cut
		mm	mm			
A0018790	ISO9	10	10	RH	P25	Steel
A0018791	ISO9	12	12	RH	P25	Steel
A0020710	ISO9	16	16	RH	P25	Steel
A0018792	ISO9	20	20	RH	P25	Steel
A0020716	ISO9	25	25	RH	P25	Steel
A0020705	ISO9	10	10	RH	K20	Cast Iron
P4RK20	ISO9	12	12	RH	K20	Cast Iron
P5RK20	ISO9	16	16	RH	K20	Cast Iron
P6RK20	ISO9	20	20	RH	K20	Cast Iron
P8RK20	ISO9	25	25	RH	K20	Cast Iron

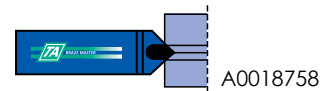
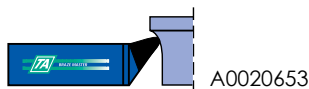

Cranked Round Nose Roughing (Tool A)					
System Code	Shank Height	Shank Width	Direction	Grade	Used to Cut
	mm	mm			
A0020653	10	10	RH	P25	Steel
A0020655	12	12	RH	P25	Steel
A0020657	16	16	RH	P25	Steel
A0020659	20	20	RH	P25	Steel
A0020661	25	25	RH	P25	Steel

Chamfering (Tool F)						
System Code	Designation	Shank Height	Shank Width	Direction	Grade	Used to Cut
		mm	mm			
A0018758	ISO10	16	10	Neutral	P25	Steel
H0001570	ISO10	20	12	Neutral	P25	Steel
A0018759	ISO10	25	16	Neutral	P25	Steel

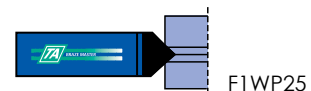
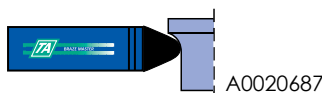

Straight Round Nose Roughing (Tool C)					
System Code	Shank Height	Shank Width	Direction	Grade	Used to Cut
	mm	mm			
A0020687	10	10	Neutral	P25	Steel
A0018749	12	12	Neutral	P25	Steel
A0020690	16	16	Neutral	P25	Steel
A0020692	20	20	Neutral	P25	Steel
A0018750	25	25	Neutral	P25	Steel

Chamfering Tool F with Full Carbide Head						
System Code	Designation	Shank Height	Shank Width	Direction	Grade	Used to Cut
		mm	mm			
F1WP25	ISO10	6	6	Neutral	P25	Steel
A0018756	ISO10	10	10	Neutral	P25	Steel
A0018757	ISO10	12	12	Neutral	P25	Steel



A0018778



Threading Tools (K)						
System Code	Designation	Shank Height	Shank Width	Direction	Grade	Used to Cut
		mm	mm			
A0018778	ISO13	20	12	RH 60°	P25	Steel
A0018781	ISO13	25	16	RH 60°	P25	Steel
A0018777	ISO13	20	12	RH 55°	P25	Steel
A0018780	ISO13	25	16	RH 55°	P25	Steel
A0018776	ISO13	20	12	RH 60°	K20	Cast Iron
A0018779	ISO13	25	16	RH 60°	K20	Cast Iron



Knurls Included G0009392

Straight Knurling Holder (Disposable)	
System Code	Size of Holder
G0009392	12 x 12 x 100



A0018782



Knurls Included Knurl size : 19x9.5x6.4

G0009384

Internal Threading Tools (KI)						
System Code	Designation	Shank Height	Shank Width	Direction	Grade	Used to Cut
		mm	mm			
A0018782	ISO 14	10	10	RH 60°	P25	Steel
A0018784	ISO 14	12	12	RH 60°	P25	Steel
A0018785	ISO 14	16	16	RH 60°	P25	Steel
A0018787	ISO 14	20	20	RH 60°	P25	Steel
A0018733	ISO 14	10	10	RH 55°	P25	Steel
A0018783	ISO 14	12	12	RH 55°	P25	Steel
A0018734	ISO 14	16	16	RH 55°	P25	Steel
A0018786	ISO 14	20	20	RH 55°	P25	Steel

Double Wheel Knurling Holders	
System Code	Size of Holder
G0009384	12 x 12 x 115

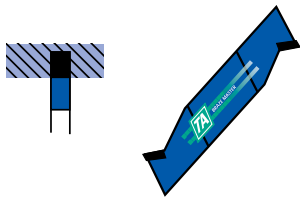

A0031204

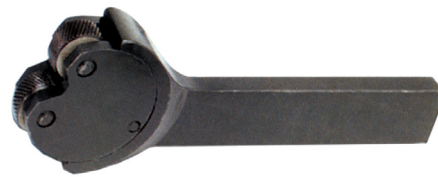

Knurls Included Knurl size : 19x9.5x6.4

A0031044

Tangential Parting Blades	
System Code	Description
A0031204	3 mm wide tip x 23.4 mm high x 170 mm long P25

Swivel Knurl Holders	
System Code	Size of Holder
A0031044	16 x 35 x 190

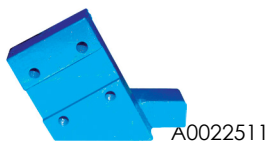

A0022511

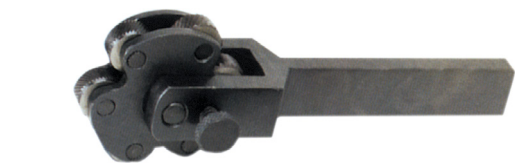

Knurls not Included Knurl size : 20 X 10 X 6

G0009382

Tangential Blade Holders	
System Code	Description
H0001448	20 mm high x 100 mm long

Revolving Head Knurling Holders	
System Code	Size of Holder
G0009382	30 x 25 mm
G0009383	32 x 20 mm

Wheels are not included.



AA20x10x6x.5P



G0007486

Spin Roll Punch Grinders

System Code	Punch Grinding Range	Length	Width	Height
	mm	mm	mm	mm
G0007486	3ø - 30ø	165	165	115

Piercing Punches (Type PP)

DIN 9861 HWS Material

AA20x10x6x.5P



Hardened and ground. HWS - 12% Chrome Steel. Hardness: Shaft HRC 62 ±2, Head HRC 55 ±5. Standard Length: 70 mm Increments: 0.1 mm. Also available in 80 mm and 100 mm lengths. Form D.

Order Example:

- 1) 10 of PP 2X70
= 10 of 12% Chrome Steel Piercing Punches 2 mm Ø x 70 mm long.
- 2) 10 off PP 3.6X80
= 10 of 12% chrome steel piercing punches 3.6 mm Ø x 80 mm long.

Piercing Punches (Type PP)

Ø d1 h6	Ø d2	k	L 0/+0.5	L 0/+0.5	L 0/+0.5
mm	mm	mm	mm	mm	mm
1.0 - 1.1	1.8	0.5	70	80	100
1.2 - 1.3	2.0	0.5	70	80	100
1.4 - 1.5	2.2	0.5	70	80	100
1.6 - 1.7	2.5	0.5	70	80	100
1.8 - 1.9	2.8	0.5	70	80	100
2.0	3.0	0.5	70	80	100
2.1 - 2.2	3.2	0.5	70	80	100
2.3 - 2.5	3.5	0.5	70	80	100
2.6 - 2.9	4.0	0.5	70	80	100
3.0 - 3.4	4.5	0.5	70	80	100
3.5 - 3.9	5.0	0.5	70	80	100
4.0 - 4.4	5.5	0.5	70	80	100
4.5 - 4.9	6.0	0.5	70	80	100
5.0 - 5.4	6.5	0.5	70	80	100
5.5 - 5.9	7.0	0.5	70	80	100
6.0 - 6.4	8.0	0.5	70	80	100
6.5 - 7.4	9.0	1.0	70	80	100
7.5 - 8.4	10.0	1.0	70	80	100
8.5 - 9.4	11.0	1.0	70	80	100
9.5 - 10.4	12.0	1.0	70	80	100
10.5 - 11.4	13.0	1.0	70	80	100
11.5 - 12.4	14.0	1.0	70	80	100
12.5 - 13.4	15.0	1.0	70	80	100
13.5 - 14.4	16.0	1.0	70	80	100
14.5 - 15.0	17.0	1.5	70	80	100

Knurls (HSS)

System Code	Description	Ø	Width	Bore	Pitch
		mm	mm	mm	mm
AA20x10x6x.5P	AA Straight	20	10	6	0.5
AA20x10x6x.6P	AA Straight	20	10	6	0.6
AA20x10x6x.8P	AA Straight	20	10	6	0.8
AA20x10x6x1P	AA Straight	20	10	6	1
AA20x10x6x1.2P	AA Straight	20	10	6	1.2
AA20x10x6x1.6P	AA Straight	20	10	6	1.6
BR20x10x6x.6P	BR Right Hand	20	10	6	0.6
BR20x10x6x.8P	BR Right Hand	20	10	6	0.8
BR20x10x6x1P	BR Right Hand	20	10	6	1
BR20x10x6x1.2P	BR Right Hand	20	10	6	1.2
BR20x10x6x1.6P	BR Right Hand	20	10	6	1.6
BR20x10x6x2P	BR Right Hand	20	10	6	2
BL20x10x6x.6P	BL Left Hand	20	10	6	0.6
BL20x10x6x.8P	BL Left Hand	20	10	6	0.8
BL20x10x6x1P	BL Left Hand	20	10	6	1
BL20x10x6x1.2P	BL Left Hand	20	10	6	1.2
BL20x10x6x1.6P	BL Left Hand	20	10	6	1.6
BL20x10x6x2P	BL Left Hand	20	10	6	2
BR19x9.5x6.4F	Right Hand	19	9.5	6.4	Fine
BR19x9.5x6.4M	Right Hand	19	9.5	6.4	Medium
BR19x9.5x6.4C	Right Hand	19	9.5	6.4	Coarse
BL19x9.5x6.4F	Left Hand	19	9.5	6.4	Fine
BL19x9.5x6.4M	Left Hand	19	9.5	6.4	Medium
BL19x9.5x6.4C	Left Hand	19	9.5	6.4	Coarse

Precision Punch Former and Grinding Wheel Form Dressers

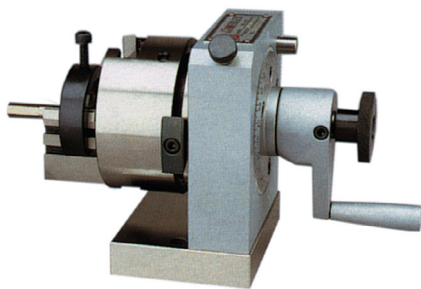

PFQ

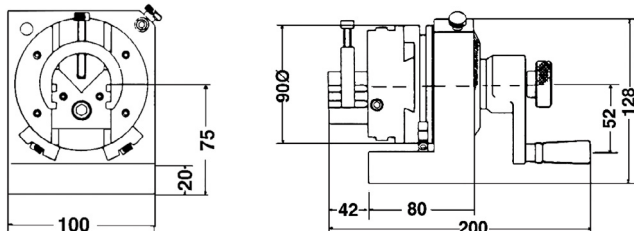

System Code: PFQ
Punch Body Diameter: 4-25 mm
Minimum Length of Punch Body: 22 mm
V-Block Travel - Z-Axis: 25 mm
V-Block Travel - X-Axis: 25 mm
Length of V Block: 30 mm
Centre Height: 80 mm
Dial Graduations: 360° x 1° Increments
Indexing Positions: 24 Divisions = 15° ± 10"

MACHINE TOOLING

Piercing Punches (Type PP)					
Ø d1 h6	Ø d2	k	L0/+0.5	L0/+0.5	L0/+0.5
mm	mm	mm	mm	mm	mm
15.1- 16	18.0	1.5	70	80	100
16.1- 17	19.0	1.5	70	80	100
17.1- 18	20.0	1.5	70	80	100
18.1- 19	21.0	1.5	70	80	100
19.1- 20	22.0	1.5	70	80	100
20.1- 22	22.0	1.5	70	80	100

Also available in WS-special steel and HSS-high speed steel.

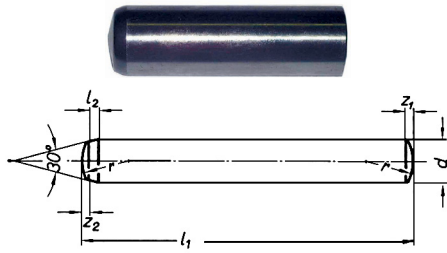

Hardened to HRC 60 ± 2

Hardened, Ground and Lapped Dowel Pins (DIN 6325)				
Dimensions	l ₂	r	Z ₁	Z ₂
d m6				
0.8	0.4	0.8	0.12	0.06
1	0.4	1	0.15	0.08
1.5	0.5	1.6	0.23	0.12
2	0.6	2	0.3	0.18
2.5	0.7	2.5	0.4	0.25
3	0.8	3	0.45	0.3
4	1	4	0.6	0.4
5	1.2	5	0.75	0.5
6	1.5	6	0.9	0.6
8	1.8	8	1.2	0.8
10	2	10	1.5	1
12	2.5	12	1.8	1.3
13	2.5	12	2	1.3
14	2.5	16	2	1.3
16	3	16	2.5	1.7
20	4	20	3	2

Dowel Pins		
System Code	Ø	Length
	mm	mm
DP2x10	2	10
DP2x12	2	12
DP2x14	2	14
DP2x16	2	16
DP2x18	2	18
DP2x20	2	20
DP2x24	2	24
DP2x28	2	28
DP2x30	2	30
DP2x32	2	32
DP2x36	2	36
DP3x10	3	10
DP3x12	3	12
DP3x14	3	14
DP3x16	3	16
DP3x18	3	18
DP3x20	3	20
DP3x24	3	24
DP3x28	3	28
DP3x30	3	30
DP3x32	3	32
DP3x36	3	36
DP3x40	3	40
DP4x10	4	10
DP4x12	4	12

Dowel Pins		
System Code	Ø	Length
	mm	mm
DP4x14	2	10
DP4x16	2	12
DP4x18	2	14
DP4x20	2	16
DP4x24	2	18
DP4x28	2	20
DP4x30	2	24
DP4x32	2	28
DP4x36	2	30
DP4x40	2	32
DP4x45	2	4
DP4x50	3	6
DP4x55	3	10
DP4x60	3	12
DP5x10	3	3
DP5x12	3	14
DP5x14	3	16
DP5x16	3	18
DP5x18	3	20
DP5x20	3	24
DP5x24	3	28
DP5x28	3	30
DP5x30	3	32
DP5x32	3	36
DP5x36	3	40
DP5x40	4	10

Dowel Pins		
System Code	Ø	Length
	mm	mm
DP5x45	5	45
DP5x50	5	50
DP5x55	5	55
DP5x60	5	60
DP5x70	5	70
DP5x80	5	80
DP6x10	6	10
DP6x12	6	12
DP6x14	6	14
DP6x16	6	16
DP6x18	6	18
DP6x20	6	20
DP6x24	6	24
DP6x28	6	28
DP6x30	6	30
DP6x32	6	32
DP6x36	6	36
DP6x40	6	40
DP6x45	6	45
DP6x50	6	50
DP6x55	6	55
DP6x60	6	60
DP6x70	6	70
DP6x80	6	80
DP6x90	6	90
DP8x18	8	18
DP8x20	8	20
DP8x24	8	24
DP8x28	8	28
DP8x30	8	30
DP8x32	8	32
DP8x36	8	36
DP8x40	8	40
DP8x45	8	45
DP8x50	8	50
DP8x55	8	55
DP8x60	8	60
DP8x70	8	70
DP8x80	8	80
DP8x90	8	90
DP8x100	8	100
DP10x20	10	20
DP10x24	10	24
DP10x28	10	28
DP10x30	10	30
DP10x32	10	32
DP10x36	10	36
DP10x40	10	40
DP10x45	10	45
DP10x50	10	50
DP10x55	10	55
DP10x60	10	60
DP10x70	10	70
DP10x80	10	80
DP10x90	10	90
DP10x100	10	100
DP10x120	10	120
DP12x20	12	20
DP12x24	12	24
DP12x28	12	28
DP12x30	12	30
DP12x32	12	32

Dowel Pins		
System Code	Ø	Length
	mm	mm
DP12x36	12	36
DP12x40	12	40
DP12x45	12	45
DP12x50	12	50
DP12x55	12	55
DP12x60	12	60
DP12x70	12	70
DP12x80	12	80
DP12x90	12	90
DP12x100	12	100
DP12x120	12	120
DP12x130	12	130
DP12x140	12	140
DP12x150	12	150
DP14x40	14	40
DP14x45	14	45
DP14x50	14	50
DP14x55	14	55
DP14x60	14	60
DP14x70	14	70
DP14x80	14	80
DP14x90	14	90
DP14x100	14	100
DP14x120	14	120
DP14x130	14	130
DP14x140	14	140
DP14x150	14	150
DP16x45	16	45
DP16x50	16	50
DP16x55	16	55
DP16x60	16	60
DP16x70	16	70
DP16x80	16	80
DP16x90	16	90
DP16x100	16	100
DP16x120	16	120
DP16x130	16	130
DP16x140	16	140
DP16x150	16	150
DP18x45	18	45
DP18x50	18	50
DP18x55	18	55
DP18x60	18	60
DP18x70	18	70
DP18x80	18	80
DP18x90	18	90
DP18x100	18	100
DP18x120	18	120
DP18x130	18	130
DP18x140	18	140
DP18x150	18	150
DP20x45	20	45
DP20x50	20	50
DP20x55	20	55
DP20x60	20	60
DP20x70	20	70
DP20x80	20	80
DP20x90	20	90
DP20x100	20	100
DP20x120	20	120
DP20x130	20	130
DP20x140	20	140
DP20x150	20	150



Threaded Hardened, Ground and Lapped Dowel Pins to DIN 7979 (Type TDP)

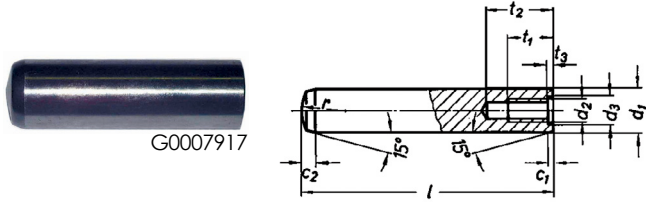

G0007917

For use in blind holes. With a flat ground along the length to prevent compression of air. Hardened to HRC 60 ±2

d ₁ M6	6	8	10	12	13	14	16	20
d ₁	M4	M5	M6	M8	M8	M8	M10	M12
d ₂	4.3	5.3	6.4	8.4	9	9.8	10.5	13
r ₁	6	8	10	12	13	14	16	20
f ₁	7	9	10	13	14	15	17	20
f ₂	11	13	16	21	21	23	26	31
f ₃	1	1.2	1.02	1.2	1.3	1.3	1.5	1.05
c-max.	0.8	1	1.02	1.6	1.6	1.8	2	2.5
c-max.	2.1	2.6	3	3.8	4.1	4.4	4.7	6

Dowel Pins		
System Code	Ø	Length
	mm	mm
G0007917	6	20
G0007918	6	24
G0007919	6	28
G0007920	6	32
G0007921	6	36
A0034283	6	40
TDP6x45	6	45
G0007922	6	50
G0007929	8	36
G0007930	8	40
TDP8x45	8	45
G0007931	8	50
TDP8x55	8	55
G0007932	8	60
TDP8x70	8	70
G0007933	8	80
TDP8x90	8	90
TDP8x100	8	100
TDP8x120	8	120
G0007896	10	20
A0034276	10	24
A0034277	10	28
G0007503	10	32
A0034278	10	36
A0034507	10	40
TDP10x45	10	45
A0034279	10	50
TDP10x55	10	55
G0007897	10	60
G0007898	10	70
TDP10x80	10	80
G0007899	10	90
G0007895	10	100
TDP10x120	10	120
TDP10x140	10	140
TDP12x20	12	20
TDP12x24	12	24
TDP12x28	12	28
G0007504	12	32
TDP12x36	12	36
G0007902	12	40
TDP16x140	8	36
G0007914	8	40
TDP20x45	8	45
TDP20x50	8	50
TDP20x55	8	55
G0007915	8	60

Dowel Pins		
System Code	Ø	Length
	mm	mm
TDP6x70	6	70
G0007923	6	80
TDP6x90	6	90
TDP6x100	6	100
G0007925	6	20
G0007926	6	24
G0007927	6	28
G0007928	6	32
G0007903	8	36
TDP12x50	8	40
TDP12x55	8	45
G0007904	8	50
TDP12x70	8	55
G0007905	8	60
G0007906	8	70
G0007900	8	80
G0007901	8	90
TDP12x140	8	100
G0007907	10	120
TDP14x36	10	20
TDP14x40	10	24
TDP14x45	10	28
G0007908	10	32
TDP14x55	10	36
TDP14x60	10	40
TDP14x70	10	45
TDP14x80	10	50
TDP14x90	10	55
TDP14x100	10	60
TDP14x120	10	70
TDP14x140	10	80
G0007910	10	90
TDP16x45	10	100
G0007911	10	120
TDP16x55	12	140
G0007912	12	20
TDP16x70	12	24
TDP16x80	12	28
TDP16x90	12	32
G0007909	12	36
TDP16x120	12	40
TDP20x70	8	100
G0007916	8	120
TDP20x90	10	20
G0007913	10	24
TDP20x120	10	28
TDP20x140	10	32

DIN 1530



EPN2x100

Ejector Pins (Form A)			
System Code	Type	Ø	Length
	mm	mm	mm
EPN2x100	Nitrided	2	100
G0007649	Nitrided	2	125
G0007650	Nitrided	2	160
G0007647	Nitrided	2.5	100
EPN2.5x125	Nitrided	2.5	125
G0007648	Nitrided	2.5	160
EPN2.5x200	Nitrided	2.5	200
EPN3x100	Nitrided	3	100
EPN3x125	Nitrided	3	125
EPN3x160	Nitrided	3	160
EPN3x200	Nitrided	3	200
EPN3.2x100	Nitrided	3.2	100
G0007657	Nitrided	4	100
A0033161	Nitrided	4	125
G0007934	Nitrided	4	160
G0007658	Nitrided	4	200
EPN4x250	Nitrided	4	250
G0007659	Nitrided	5	100
G0007660	Nitrided	5	125
G0007661	Nitrided	5	160
G0007662	Nitrided	5	200
A0033162	Nitrided	5	250
G0007553	Nitrided	6	100
G0007664	Nitrided	6	125
G0007665	Nitrided	6	160
G0007666	Nitrided	6	200
A0034463	Nitrided	6	250
A0033163	Nitrided	8	100
G0007667	Nitrided	8	125
G0007668	Nitrided	8	160
EPN8x200	Nitrided	8	200
G0007669	Nitrided	8	250
G0007636	Nitrided	10	100
G0007637	Nitrided	10	125
G0007638	Nitrided	10	160
G0007639	Nitrided	10	200
G0007640	Nitrided	10	250
G0007642	Nitrided	12	160
EPH2x100	Through Hardened	2	100
G0007677	Through Hardened	2	125
EPH2x160	Through Hardened	2	160
G0007678	Through Hardened	2	200
EPH2.5x100	Through Hardened	2.5	100
EPH2.5x125	Through Hardened	2.5	125
EPH2.5x160	Through Hardened	2.5	160
EPH2.5x200	Through Hardened	2.5	200
G0007680	Through Hardened	3	100
EPH3x125	Through Hardened	3	125
G0007681	Through Hardened	3	160
G0007682	Through Hardened	3	200
G0007683	Through Hardened	3	250
EPH4x100	Through Hardened	4	100
EPH4x125	Through Hardened	4	125
EPH4x160	Through Hardened	4	160
EPH4x200	Through Hardened	4	200
EPH4x250	Through		

Ejector Pins (Form A)			
System Code	Type	Ø	Length
	mm	mm	mm
G0007689 EPTH6x250	Through Hardened Through Hardened	6 6	200 250
G0007690 G0007691 G0007692 G0007693 G0007694	Through Hardened Through Hardened Through Hardened Through Hardened Through Hardened	8 8 8 8 8	100 125 160 200 250
G0007670 G0007671 G0007672 G0007673 G0007674	Through Hardened Through Hardened Through Hardened Through Hardened Through Hardened	10 10 10 10 10	100 125 160 200 250

Ground Shoulder Material: SCM45 HRC 38-40

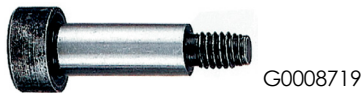

G0008719

Shoulder Bolts				
System Code	Thread	Shoulder Ø e9	Shoulder Length ± 0.1	Head
		mm	mm	
G0008719 G0008720 G0008721 G0008722 G0008723 G0008724	M5 M5 M5 M5 M5 M5	6 6 6 6 6 6	15 20 25 30 35 40	1 1 1 1 1 1
G0008725 G0008726 G0008727 G0008728 G0008729	M6 M6 M6 M6 M6	8 8 8 8 8	15 20 25 30 35	13 13 13 13 13
G0008730 G0008731 G0008732 G0008733	M6 M6 M6 M6	8 8 8 8	40 45 50 55	13 13 13 13
G0008734 G0008735 G0008736 G0008737 G0008738 G0008739	M8 M8 M8 M8 M8 M8	10 10 10 10 10 10	25 30 35 40 45 50	16 16 16 16 16 16
G0008741 G0008742 G0008743 G0008744	M8 M8 M8 M8	10 10 10 10	60 70 75 80	16 16 16 16
G0008693 G0008694 G0008695 G0008696 G0008697	M10 M10 M10 M10 M10	12 12 12 12 12	25 30 35 40 45	18 18 18 18 18
G0008698 G0008699 G0008700 G0008701 G0008692	M10 M10 M10 M10 M10	12 12 12 12 12	50 60 70 85 110	18 18 18 18 18
G0008703 G0008704 G0008705 G0008706 G0008707	M10 M10 M10 M10 M10	13 13 13 13 13	25 30 35 40 45	18 18 18 18 18
G0008708 G0008709 G0008710 G0008711 G0008702	M10 M10 M10 M10 M10	13 13 13 13 13	50 60 70 85 110	18 18 18 18 18
G0008714 G0008715 G0008716 G0008717 G0008718 G0008712	M12 M12 M12 M12 M12 M12	16 16 16 16 16 16	50 60 65 70 90 100	24 24 24 24 24 24



Bordignon Rectangular Section Die Springs to ISO 10243



These are rectangular wire section compression springs with rounded edges. For the same dimensions, each spring has four different load and stroke values, according to the series they belong to. The four series are distinguished by an identifying colour. In order to identify a spring using the tables, all that is necessary is to specify the following three parameters: Load Series & External Diameter & Free Length.

The code indicates the values of all three parameters in the sequence:

- Series:** 1S Green Colour: Light-Load
 2S Blue Colour: Medium-Load
 3S Red Colour: Heavy-Load
 4S Yellow Colour: Extra Heavy-Load
 5S Bronze: Super Heavy-Duty (on Request)

External Diameter: Diameter of the hole or housing that the spring will fit into.

Free Length: Length of the spring at rest.

Spring Rate: Load - (n Newton) - Necessary to deflect the spring by 1 mm (1 Newton = 0.102 kg).

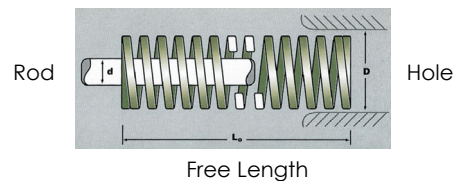

When Selecting and Using Die Springs, the Following Points are recommended:

- Select the lightest and longest springs that the working conditions allow.
- Operating travel must never exceed the maximum deflection indicated. Ensure that this is so each time the die is sharpened.
- Pre-load each spring in the tool by at least 5% of the free length, with a minimum of 2 mm.
- Provide for an even base for each spring.
- Provide proper guidance to avoid buckling



**Hole Ø D - 10 mm. Rod Ø d - 5 mm
Wire Section - 1,7 mm x 1 mm**

Series 1S Light Load - Green								
System Code	Free Length	Spring Rate N	Rec. Deflection 30%		Max. Deflection 40%		Deflection Solid	
	mm	mm	N	mm	N	mm	N	mm
A0031935	25	10.0	75.0	7.5	100	10.0	130	13
G0007005	32	8.5	81.6	9.6	109	12.8	136	16
G0007006	38	6.8	77.5	11.4	103	15.2	136	20
G0007007	44	6.0	79.2	13.2	106	17.6	144	24
G0007008	51	5.0	76.5	15.3	102	20.4	135	27
G0007009	64	4.3	82.6	19.2	110	25.6	151	35
G0007010	76	3.2	73.0	22.8	97.3	30.4	125	39
G0007011	305	1.1	101	91.5	134	122	169	154

**Hole Ø D - 12.5 mm. Rod Ø d - 6.3 mm
Wire Section - 2.4 mm x 1.25 mm**

System Code	Free Length	Spring Rate N	Max. Reflection 30%		Max. Reflection 40%		Deflection Solid	
	mm		N	mm	N	mm	N	mm
G0007012	25	17.9	134	7.5	179	10.0	233	13
G0007013	32	16.4	157	9.6	210	12.8	279	17
G0007014	38	13.6	155	11.4	207	15.2	286	21
G0007015	44	12.1	160	13.2	213	17.6	315	26
G0007016	51	11.4	174	15.3	233	20.4	331	29
G0007017	64	9.3	179	19.2	238	25.6	344	37
G0007018	76	7.1	162	22.8	216	30.4	298	42
G0007019	89	5.4	144	26.7	192	35.6	270	50
G0007020	305	1.4	128	91.5	171	122	227	162

**Hole Ø D - 16 mm. Rod Ø d - 8 mm
Wire Section - 3.2 mm x 1.5 mm**

1S16025	25	23.4	176	7.5	234	10.0	304	13
1S16032	32	22.9	202	9.6	293	12.8	389	17
G0007023	38	19.3	202	11.4	293	15.2	386	20
G0007024	44	17.1	226	13.2	301	17.6	428	25
G0007025	51	15.7	240	15.3	320	20.4	424	27

G0007027	64	10.7	205	19.2	274	25.6	385	36
G0007027	76	10	228	22.8	304	30.4	430	43
G0007028	89	8.6	230	26.7	306	35.6	447	52
G0007029	102	7.8	239	30.6	318	40.8	452	58
G0007030	305	2.5	229	91.5	305	122	415	166

**Hole Ø D - 20 mm. Rod Ø d - 10 mm
Wire Section - 4 mm x 2 mm**

G0007031	25	55.8	419	7.5	558	10	725	13
G0007032	32	45	432	9.6	576	12.8	465	17
G0007033	38	33.3	380	11.4	506	15.2	666	20
G0007034	44	30	396	13.2	528	17.6	720	24
G0007035	51	24.5	375	15.3	500	20.4	662	27

G0007036	64	20	384	19.2	512	25.6	700	35
G0007037	76	16	365	22.8	486	30.4	640	40
G0007038	89	14	374	26.7	498	35.6	686	49
G0007039	102	12	367	30.6	490	40.8	660	55
G0007040	115	10.9	375	34.5	501	46	676	62

G0007041	127	9.5	362	38.1	483	50.8	675	71
G0007042	139	8.4	350	41.7	467	55.6	638	76
G0007043	152	7.5	342	45.6	456	60.8	608	81
G0007044	305	4	366	91.5	488	122	672	168

**Hole Ø D - 25 mm. Rod Ø d - 12.5 mm
Wire Section - 5.4 mm x 2.7 mm**

G0007045	25	100	750	7.5	1000	10	1200	12
G0007046	32	80.3	771	9.6	1028	12.8	1285	16
G0007047	38	62	707	11.4	942	15.2	1178	19
G0007048	44	52.9	698	13.2	931	17.6	1164	22
G0007049	51	44	673	15.3	898	20.4	1100	25

G0007050	64	35.2	676	19.2	901	25.6	1197	34
G0007051	76	28	638	22.8	851	30.4	1064	38
G0007052	89	24	641	26.7	854	35.6	1152	48
G0007053	102	21.1	646	30.6	861	40.8	1139	54
G0007054	115	18.7	645	34.5	860	46	1141	61

G0007055	127	16.7	636	38.1	848	50.8	1152	69
G0007056	139	15.3	638	41.7	851	55.6	1148	75
G0007057	152	14	638	45.6	851	60.8	1134	81
G0007058	178	12.5	668	53.4	890	71.2	1200	96
G0007059	203	10.4	633	60.9	844	81.2	1144	110

G0007060	305	7	641	91.5	854	122	1176	168
----------	-----	---	-----	------	-----	-----	------	-----

**Hole Ø D - 32 mm. Rod Ø d - 16 mm
Wire Section - 6.9 mm x 3.25 mm**

System Code	Free Length	Spring Rate N	Max. Reflection 30%		Max. Reflection 40%		Deflection Solid	
	mm		N	mm	N	mm	N	mm
G0007061	38	94	072	11.4	1429	15.2	1692	18
1S32054	44	79.5	1049	13.2	1399	17.6	1749	22
G0007063	51	67	1025	15.3	1367	20.4	1675	25
G0007064	64	53	1018	19.2	1357	25.6	1802	34
G0007065	76	44	1003	22.8	1338	30.4	1760	40

G0007066	89	37.2	993	26.7	1324	35.6	1786	48
G0007067	102	32	979	30.6	1306	40.8	1760	55
G0007068	115	29	1001	34.5	1334	46	1827	63
G0007069	127	25	953	38.1	1270	50.8	1725	69
G0007070	139	23	959	41.7	1279	55.6	1771	77

G0007071	152	21.5	980	45.6	1307	60.8	1742	81
G0007072	178	18.2	972	53.4	1296	71.2	1729	95
G0007073	203	15.8	962	60.9	1283	81.2	1770	112
G0007074	254	12.5	963	76.2	1270	102	1788	143
G0007075	305	10.3	942	91.5	1257	122	1803	175

**Hole Ø D - 40 mm. Rod Ø d - 20 mm
Wire Section - 8.1 mm x 3.9 mm**

G0007076	51	92	1408	15.3	1877	20.4	2300	25
G0007077	64	73	1402	19.2	1869	25.6	2409	33
1S38275	76	63	1436	22.8	1915	30.4	2457	39
G0007079	89	5130	1362	26.7	1816	35.6	2397	47
G0007080	102	43	1306	30.6	1754	40.8	2322	54

G0007081	115	39.6	1366	34.5	1822	46	2416	61
G0007082	127	37	1410	38.1	1880	50.8	2442	66
G0007083	139	32	1334	41.7	1779	55.6	2432	76
G0007084	152	28	1277	45.6	1702	60.8	2268	81
G0007085	178	25.2	1346	53.4	1794	71.2	2344	93

G0007086	203	22.7	1382	60.9	1843	81.2	2497	110
G0007087	254	17	1295	76.2	1727	102	2312	136
G0007088	305	14.8	1354	91.5	1806	122	2412	163

**Hole Ø D - 50 mm. Rod Ø d 25 mm
Wire Section - 11.15 mm x 5.35 mm**

G0007089	64	156	2995	19.2	3994	25.6	4836	31
G0007090	76	125	2852	22.8	3800	30.4	4500	36
G0007091	89	109	2910	26.7	3880	35.6	4796	44
G0007092	102	94	2876	30.6	3835	40.8	4606	49
G0007093	115	81	2795	34.5	326	46.0	4860	60

G0007094	127	71	2705	38.1	3607	50.8	4544	64
G0007095	139	66.5	2773	41.7	3697	55.6	4655	70
G0007096	152	60	2736	45.6	3648	60.8	4620	77
G0007097	178	52	2777	53.4	3702	71.2	4888	94
G0007098	203	44	2680	60.9	3573	81.2	4620	105

G0007099	229	38.2	2624	68.7	3499	91.6	4813	126
1S57252	254	35	2667	76.2	3556	102	4795	137
G0007101	305	28.5	2608	91.5	3477	122	4788	168

**Hole Ø D - 63 mm. Rod Ø d - 38 mm
Wire Section - 11.5 mm x 7.6 mm**

G0007102	76	189	4309	22.8	5746	30.4	7182	38
G0007103	89	158	4219	26.7	5625	35.6	7110	45
G0007104	102	131	4009	30.6	4345	40.8	6812	52
G0007105	115	116	4002	34.5	5336	46	6960	60
G0007106	127	103	3924	80.1	5232	50.8	6489	63

G0007107	152	84.3	3844	45.6	5125	60.8	6575	78
G0007108	178	71.5	3818	53.4	5091	71.2	6364	89
G0007109	203	61.7	3758	60.9	5010	81.2	6664	108
G0007110	254	47	3581	76.2	4775	102	6439	137
G0007111	305	38.2	3495	91.5	4660	122	6227	163



Series 2S • Medium Load - Colour Blue



G0007112

**Hole Ø D - 10 mm. Rod Ø d - 5 mm
Wire Section - 1.8 mm x 1.2 mm**

System Code	Free Length mm	Spring Rate N/mm	Max. Reflection 25%		Max. Reflection 37%		Deflection Solid	
			N	mm	N	mm	N	mm
G0007112	25	16	100	6.3	150	9.4	192	12
G0007113	32	13	104	8	156	12	182	14
G0007114	38	11.9	113	9.5	170	14.3	226	19
G0007115	44	10.3	113	11	170	16.5	237	23
G0007116	51	8.9	113	12.8	170	19.1	240	27
G0007117	64	7.5	120	16	180	24	233	31
G0007118	76	5.3	101	19	151	28.5	196	37
G0007001	305	1.6	122	76.3	183	114	219	137

**Hole Ø D - 12.5 mm. Rod Ø d - 6.3 mm
Wire Section - 2.4 mm x 1.6 mm**

G0007119	25	30	188	6.3	281	9.4	300	10
G0007120	32	24.8	198	8	298	12	322	13
G0007121	38	21.4	203	9.5	305	14.3	342	16
G0007122	44	18.5	204	11	305	16.5	370	20
G0007123	51	15.5	198	12.8	296	19.1	388	25
G0007124	64	12.1	194	16.0	290	24	339	28
G0007125	76	10.2	194	19.0	291	28.5	347	34
G0007126	90	8.4	187	22.3	280	33.4	344	41
G0007127	305	2.1	160	76.3	240	114	269	128

**Hole Ø D - 16 mm. Rod Ø d - 8 mm
Wire Section - 3.2 mm x 1.9 mm**

G0007128	25	49.4	309	6.3	463	9.4	543	11
G0007129	32	37.1	297	8	445	12	557	15
G0007130	38	33.9	322	9.5	483	14.3	610	18
G0007131	44	30	330	11.0	495	16.5	660	22
G0007132	51	26.4	337	12.8	505	19.1	634	24
G0007133	64	20.5	328	16	492	24	656	32
G0007134	76	17.8	338	19	507	28.5	641	36
G0007135	90	15.2	338	22.3	507	33.4	654	43
G0007136	101	13.5	344	25.5	516	38.3	635	47
G0007137	305	4.8	366	76.3	549	114	667	139

**Hole Ø D - 20 mm. Rod Ø d - 10 mm
Wire Section - 4.05 mm x 2.45 mm**

G0007138	25	98	613	6.3	919	9.4	980	10
G0007139	32	72.6	581	8	871	12	944	13
G0007140	38	56	532	9.5	798	14.3	896	16
G0007141	44	47.5	523	11	784	16.5	903	19
G0007142	51	41.7	532	12.8	798	19.1	876	21
G0007143	64	32.3	517	16	775	24	904	28
G0007144	76	25.1	477	19	715	28.5	828	33
G0007145	90	22	490	22.3	734	33.4	902	41
G0007146	101	19.8	505	25.5	757	38.3	950	48
G0007147	115	18.1	520	28.8	781	43.1	996	55

G0007148	127	16.6	527	31.8	791	47.6	1013	61
G0007149	139	15.1	525	34.8	787	52.1	1012	67
G0007150	152	13.2	502	38	752	57	977	74
G0007151	305	6.1	465	76.3	698	114	891	146

**Hole Ø D - 25 mm. Rod Ø d - 12.5 mm
Wire Section - 5.4 mm x 3.1 mm**

System Code	Free Length mm	Spring Rate N/mm	Max. Reflection 25%		Max. Reflection 37%		Deflection Solid	
			N	mm	N	mm	N	mm
G0007152	25	147	919	6.3	1378	9.4	1617	11
G0007153	32	118	944	8	1416	12	1534	13
G0007154	38	93	884	9.5	1325	14.3	1674	18
G0007155	44	80.8	889	11	1333	16.5	1697	21
G0007156	51	68.6	875	12.8	1312	19.1	1578	23
G0007157	64	53	848	16	1272	24	1590	30
G0007158	76	43.2	821	19	1231	28.5	1512	35
G0007159	90	38.2	850	22.3	1275	33.4	1643	43
G0007160	101	33	842	25.5	1262	38.3	1617	49
G0007161	115	28	805	28.8	1208	43.1	1568	56
G0007162	139	25.9	822	31.8	1233	47.6	1554	60
G0007163	140	23.2	806	34.8	1209	52.1	1508	65
G0007164	152	20.8	790	38	1186	57	1477	71
G0007165	178	17.8	792	44.5	1188	66.8	1513	85
G0007166	203	15.8	802	50.8	1203	76.1	1517	96
G0007167	305	10.2	778	76.3	1167	114	1530	150

**Hole Ø D - 32 mm. Rod Ø d - 16 mm
Wire Section - 6.9 mm x 3.9 mm**

G0007155	38	185	1758	9.5	2636	14.3	3145	17
G0007169	44	158	1738	11	2607	16.5	3002	19
G0007170	51	134	1709	12.8	2563	19.1	3082	23
G0007171	64	99	1584	16	2376	24	2970	30
G0007172	76	80.5	1530	19	2294	28.5	2737	34
G0007173	89	69.1	1537	22.3	2306	33.4	2902	42
G0007174	102	58.8	1499	25.5	2249	38.3	2764	47
G0007175	115	51.5	1481	28.8	2221	43.1	2833	55
G0007176	139	44.8	1422	31.8	2134	47.6	2733	61
2S32140	140	42.3	1470	34.8	2205	52.1	2876	68
G0007178	152	37.8	1436	38	2155	57	2835	75
G0007179	178	32.5	1446	44.5	2169	66.8	2893	89
G0007180	203	28.9	1467	50.8	2200	76.1	2919	101
G0007181	254	21.4	1359	63.5	2038	95.3	2645	124
G0007182	305	18.3	1395	76.3	2093	114	2745	150

**Hole Ø D - 40 mm. Rod Ø d - 20 mm
Wire Section - 8.15 mm x 4.7 mm**

G0007183	51	182	2315	12.8	3473	19.1	3814	21
G0007184	64	140	2240	16	3360	24	3920	28
G0007185	76	108	2052	19	3078	28.5	3564	33
G0007186	89	90.7	2018	22.3	3027	33.4	3719	41
G0007187	102	81	2066	25.5	3098	38.3	3645	45
G0007188	115	71.8	2064	28.8	3096	43.1	3734	52
G0007189	127	62.7	1991	31.8	2986	47.6	3699	59
G0007190	139	57.5	1998	34.8	2997	52.1	3795	66
G0007191	152	51.6	1961	38	2941	57	3664	71
G0007192	160	47.5	1900	40	2850	60	3420	72
G0007193	178	44.1	1962	44.5	2944	66.8	3660	83
G0007194	203	36.7	1863	50.8	2794	76.1	3450	94
G0007195	254	30.1	1911	63.5	2867	95.3	3431	114
G0007196	305	24.6	1876	76.3	2814	114	3641	148

**Hole Ø D - 50 mm. Rod Ø d - 25 mm
Wire Section - 10.9 mm x 5.95 mm**

G0007197	64	209	3344	16	5016	24	6270	30
G0007198	76	168	3192	19	4788	28.5	6048	36
G0007199	89	140	3115	22.3	4673	33.4	6020	43
G0007200	102	119	3035	25.5	4552	38.3	5712	48
G0007201	115	106	3048	28.8	4571	43.1	5830	55
G0007202	127	97	3080	31.8	4620	47.6	6111	63
G0007203	139	87	3023	34.8	4535	52.1	5742	66
G0007204	152	80	3040	38	4560	57	5760	72
G0007205	160	76	3040	40	4560	60	5928	78
G0007206	178	69.5	3093	44.5	4639	66.8	5908	85
G0007207	30	59.8	3035	50.8	4552	76.1	5681	95
G0007208	229	50.9	2914	57.3	4371	85.9	5803	114
G0007209	254	43.9	2788	63.5	4181	95.3	5488	125
G0007210	305	38.6	2943	76.3	4415	114	5790	150

MACHINE TOOLING

Hole Ø D - 63 mm. Rod Ø d - 38 mm Wire Section - 11.5 mm x 9.2 mm								
System Code	Free Length	Spring Rate N	Max. Reflection 25%		Max. Reflection 37.5%		Deflection Solid	
	mm	mm	N	mm	N	mm	N	mm
G0007198	76	312	5928	19	8892	28.5	9360	30
G0007199	89	260	5785	22.3	8678	33.4	9880	38
G0007200	102	221	5636	25.5	8453	38.3	9503	43
G0007201	115	187	5376	28.8	8064	43.1	9350	50
G0007202	127	168	5334	31.8	8001	47.6	8736	52
G0007204	152	136	5168	38	7752	57	9112	67
G0007205	160	128	5120	40	7680	60	8960	70
G0007206	178	114	5073	44.5	7610	66.8	8892	78
G0007207	203	100	5075	50.8	7613	76.1	8800	88
G0007208	229	89.2	5107	57.3	7660	85.9	9098	102
G0007209	254	78.4	4978	63.5	7468	95.3	9016	115
G0007210	305	64.7	4933	76.3	7400	114	8670	134
2S51315	315	62.8	4946	78.8	7418	118	9043	144
2S51400	400	48.5	4850	100	7275	150	9555	197

Series 3S • Heavy Load - Red Colour

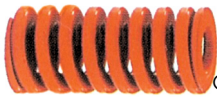

G0007225

Hole Ø D - 10 mm. Rod Ø d - 5 mm Wire Section - 1.8 mm x 1.4 mm								
System Code	Free Length	Spring Rate N	Max. Reflection 25%		Max. Reflection 37.5%		Deflection Solid	
	mm	mm	N	mm	N	mm	N	mm
G0007225	25	22.1	111	5.0	166	7.5	199	9
G0007226	32	17.5	112	6.4	168	9.6	210	12
G0007227	38	17.1	130	7.6	195	11.4	257	15
G0007228	44	15	132	8.8	198	13.2	255	17
G0007229	51	12.8	131	10.2	196	15.3	269	21
G0007230	64	10.7	137	12.8	205	19.2	278	26
G0007231	76	7.5	114	15.2	171	22.8	233	31
G0007232	305	2.1	128	61	192	91.5	256	122

Hole Ø D - 12.5 mm. Rod Ø d - 6.3 mm Wire Section - 2.5 mm x 1.9 mm								
System Code	Free Length	Spring Rate N	Max. Reflection 25%		Max. Reflection 37.5%		Deflection Solid	
	mm	mm	N	mm	N	mm	N	mm
G0007233	25	42.1	211	5.0	316	7.5	376	9
G0007234	32	33.2	212	6.4	319	9.6	432	13
G0007235	38	29.3	223	7.6	334	11.4	440	15
G0007236	44	24.6	216	8.8	325	13.2	443	18
G0007237	51	19.6	200	10.2	300	15.3	392	20
G0007238	64	15	192	12.8	288	19.2	390	26
G0007239	76	13.2	201	15.2	301	22.8	396	30
G0007240	89	11.4	203	17.8	304	26.7	399	35
G0007241	305	2.8	171	61	256	91.5	344	123

Hole Ø D - 16 mm. Rod Ø d - 8 mm Wire Section - 3 mm x 2.3 mm								
System Code	Free Length	Spring Rate N	Max. Reflection 25%		Max. Reflection 37.5%		Deflection Solid	
	mm	mm	N	mm	N	mm	N	mm
G0007242	25	75.7	379	5.0	568	7.5	681	9
G0007243	32	52.8	338	6.4	507	9.6	739	14
G0007244	38	48.5	369	7.6	553	11.4	825	17
G0007245	44	42.8	377	8.8	565	13.2	856	20
G0007246	51	37.1	378	10.2	568	15.3	779	21
G0007247	64	30.3	388	12.8	582	19.2	848	28
G0007248	76	25.7	391	15.2	586	22.8	848	33
G0007249	89	21.7	386	17.8	579	26.7	846	39
G0007250	102	19.3	394	20.4	591	30.6	849	44
G0007251	305	7.1	433	61	650	91.5	902	127

Hole Ø D - 20 mm. Rod Ø d - 10 mm Wire Section - 4.05 mm x 3.2 mm								
System Code	Free Length	Spring Rate N	Max. Reflection 25%		Max. Reflection 37.5%		Deflection Solid	
	mm	mm	N	mm	N	mm	N	mm
G0007252	25	216	1080	5	1620	7.5	1944	9
G0007253	32	168	1075	6.4	1613	9.6	1848	11
G0007254	38	129	980	7.6	1471	11.4	1677	13
G0007255	44	112	986	8.8	1478	13.2	1792	16
G0007256	51	94	959	10.2	1438	15.3	1880	20
G0007257	64	72.1	923	12.8	1384	19.2	1803	25
G0007258	76	59.7	907	15.2	1361	22.8	1731	29

Hole Ø D - 20 mm. Rod Ø d - 10 mm Wire Section - 4.05 mm x 3.2 mm								
System Code	Free Length	Spring Rate N	Max. Reflection 20%		Max. Reflection 37.5%		Deflection Solid	
	mm	mm	N	mm	N	mm	N	mm
G0007259	89	50.5	899	17.8	1348	26.7	1768	35
G0007260	102	44.2	902	20.4	1353	30.6	1768	40
G0007261	115	38.4	883	23	1325	34.5	1805	47
G0007262	127	34.1	866	25.4	1299	38.1	1773	52
G0007263	139	31.0	862	27.8	1293	41.7	1767	57
G0007264	152	28.2	857	30.4	1286	45.6	1748	62
G0007265	305	15	915	61	1373	91.5	1815	121

Hole Ø D - 25 mm. Rod Ø d - 12.5 mm Wire Section - 5.6 mm x 4.1 mm								
System Code	Free Length	Spring Rate N	Max. Reflection 20%		Max. Reflection 37.5%		Deflection Solid	
	mm	mm	N	mm	N	mm	N	mm
G0007266	25	375	1875	5	2813	7.5	3375	9
G0007267	32	297	1901	6.4	2851	9.6	3267	11
G0007268	38	219	1664	7.6	2497	11.4	3066	14
G0007269	44	187	1646	8.8	2468	13.2	2992	16
G0007270	51	156	1591	10.2	2387	15.3	2964	19
G0007271	64	123	1574	12.8	2362	19.2	3198	26
G0007272	76	99	1505	15.2	2257	22.8	2871	29
G0007273	89	84	1495	17.8	2243	26.7	2940	35
G0007274	102	73	1489	20.4	2234	30.6	2847	39
G0007275	115	65	1495	23	2243	34.5	2925	45
G0007276	127	57.7	1466	25.4	2198	38.1	2770	48
G0007277	139	52.7	1465	27.8	2198	41.7	2846	54
G0007278	152	47.8	1453	30.4	2180	45.6	2868	60
G0007279	178	41	1460	35.6	2189	53.4	2747	67
G0007280	203	35.8	1453	40.6	2180	60.9	2864	80
G0007281	305	22.9	1397	61	2095	91.5	2725	119

Hole Ø D - 32 mm. Rod Ø d - 16 mm Wire Section - 7 mm x 5.25 mm								
System Code	Free Length	Spring Rate N	Max. Reflection 20%		Max. Reflection 37.5%		Deflection Solid	
	mm	mm	N	mm	N	mm	N	mm
G0007268	38	388	2949	7.6	4423	11.4	5044	13
G0007269	44	324	2851	8.8	4277	13.2	5184	16
G0007270	51	272	2774	10.2	4162	15.3	4896	18
G0007271	64	212	2714	12.8	4070	19.2	4876	23
G0007272	76	172	2614	15.2	3922	22.8	4644	27
G0007273	89	141	2510	17.8	3765	26.7	4653	33
G0007274	102	122	2489	20.4	3733	30.6	4758	39
G0007275	115	107	2461	23	3692	34.5	4601	43
G0007276	127	93	2362	25.4	3543	38.1	4371	47
G0007277	139	86	2391	27.8	3586	41.7	4386	51
3S26151	152	78	2371	30.4	3557	45.6	4290	55
3S26176	178	67.2	2392	35.6	3588	53.4	4637	69
3S26202	203	59.1	2399	40.6	3599	60.9	4787	81
3S26252	254	46.4	2357	50.8	3536	76.2	4594	99
3S26303	305	38	2318	61	3477	91.5	4522	119

Hole Ø D - 40 mm. Rod Ø d - 20 mm Wire Section - 8.4 mm x 6.1 mm								
System Code	Free Length	Spring Rate N	Max. Reflection 20%		Max. Reflection 37.5%		Deflection Solid	
	mm	mm	N	mm	N	mm	N	mm
G0007297	51	350	3570	10.2	5355	15.3	6300	18
G0007002	64	369	3443	12.8	5165	19.2	6725	25
G0007298	76	219	3329	15.2	4993	22.8	6570	30
G0007299	89	190	3382	17.8	5073	26.7	6840	36
G0007300	102	163	3325	20.4	4988	30.6	6683	41
G0007301	115	142	3266	23	4899	34.5	6674	47
G0007302	127	128	3251	25.4	4877	38.1	6784	53
G0007303	139	115	3197	27.8	4796	41.7	6440	56
G0007304	152	105	3192	30.4	4788	45.6	6510	62
G0007305	178	89	3168	35.6	4753	53.4	6230	70
G0007306	203	77	3126	40.6	4689	60.9	6391	83
G0007307	254	61	3099	50.8	4648	76.2	6161	101
G0007308	305	51	3111	61	4667	91.5	6477	127

Hole Ø D - 50 mm. Rod Ø d - 25 mm Wire Section - 11 mm x 7.3 mm								
System Code	Free Length	Spring Rate N	Max. Reflection 20%		Max. Reflection 37.5%		Deflection Solid	
	mm	mm	N	mm	N	mm	N	mm
G0007309	64	413	5286	12.8	7930	19.2	10738	26
G0007310	76	339	5153	15.2	7729	22.8	9831	29
G0007311	89	288	5126	17.8	7690	26.7	10080	35
G0007312	102	245	4998	20.4	7497	30.6	10045	41
G0007313	115	215	4945	23	7418	34.5	10105	47

MACHINE TOOLING

Hole Ø D - 20 mm. Rod Ø d - 10 mm Wire Section - 4.05 mm x 3.2 mm								
System Code	Free Length	Spring Rate N	Max. Reflection 20%		Max. Reflection 20%		Deflection Solid	
	mm	mm	N	mm	N	mm	N	mm
G0073	127	192	4877	25.4	7315	38.1	10560	55
G0073	139	168	4670	27.8	7006	41.7	10248	61
G0073	152	154	4682	30.4	7022	45.6	10164	66
G0073	178	134	4770	35.6	7156	53.4	10050	75
G0073	203	117	4750	40.6	7125	60.9	10179	87
G0073	254	89	4521	50.8	6782	76.2	9612	108
G0073	305	73	4453	61	6680	91.5	9709	133

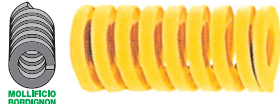

Series 4S • Extra Heavy Load - Yellow Colour

Hole Ø D - 10 mm. Rod Ø d - 5 mm Wire Section - 2 mm x 1.5 mm								
System Code	Free Length	Spring Rate N	Max. Reflection 20%		Max. Reflection 20%		Deflection Solid	
	mm	mm	N	mm	N	mm	N	mm
G007321	25	36.8	156	4.3	230	6.3	331	9
G007322	32	27.9	152	5.4	223	8.0	335	12
G007323	38	23.7	153	6.5	225	9.5	332	14
G007324	44	19.2	144	7.5	211	11	326	17
G007325	51	16.5	143	8.7	210	12.8	314	19
G007326	64	13.2	144	10.9	211	16	304	23
G007327	76	10.9	141	12.9	207	19	327	30
G007328	305	2.6	135	51.9	198	76.3	304	117

Hole Ø D - 12.5 mm. Rod Ø d - 6.3 mm Wire Section - 2.4 mm x 2 mm								
System Code	Free Length	Spring Rate N	Max. Reflection 20%		Max. Reflection 20%		Deflection Solid	
	mm	mm	N	mm	N	mm	N	mm
G007329	25	58.5	249	4.3	366	6.3	527	9
G007330	32	43.9	239	5.4	351	8	527	12
G007331	38	36	233	6.5	342	9.5	504	14
G007332	44	30.3	227	7.5	333	11	545	18
G007333	51	26.2	227	8.7	334	12.8	524	20
G007334	64	21.2	231	10.9	339	16	572	27
G007335	76	17.1	221	12.9	325	19	547	32
G007336	89	14.5	219	15.1	323	22.3	551	38
G007338	305	4.3	223	51.9	328	76.3	495	115

Hole Ø D - 16 mm. Rod Ø d - 8 mm Wire Section - 3.15 mm x 2.7 mm								
System Code	Free Length	Spring Rate N	Max. Reflection 20%		Max. Reflection 20%		Deflection Solid	
	mm	mm	N	mm	N	mm	N	mm
G007339	25	118	502	4.3	738	6.3	1180	10
G007340	32	89	484	5.4	712	8	1068	12
G007341	38	72.1	466	6.5	685	9.5	1009	14
G007342	44	60.9	456	7.5	670	11	1035	17
G007343	51	52.3	453	8.7	667	12.8	994	19
G007344	64	41.2	448	10.9	659	16	1030	25
G007345	76	34.1	441	12.9	648	19	989	29
G007346	89	29.5	446	15.1	656	22.3	1062	36
G007347	102	25.6	444	17.3	653	25.5	973	38
G007348	305	8.4	436	51.9	641	76.3	1008	120

Hole Ø D - 20 mm. Rod Ø d - 10 mm Wire Section - 4.1 mm x 3.8 mm								
System Code	Free Length	Spring Rate N	Max. Reflection 20%		Max. Reflection 20%		Deflection Solid	
	mm	mm	N	mm	N	mm	N	mm
G007349	25	293	1245	4.3	1831	6.3	2051	7
G007350	32	224	1219	5.4	1792	8	2240	10
G007351	38	177	1143	6.5	1682	9.5	2124	12
G007352	44	149	1115	7.5	1639	11	2086	14
G007003	51	128	1110	8.7	1632	12.8	2048	16
G007353	64	99	1077	10.9	1584	16	2178	22
G007354	76	81.7	1056	12.9	1552	19	2043	25
G007355	89	69.5	1052	15.1	1546	22.3	2455	31
G007356	102	60.6	1051	17.3	1545	25.5	2182	36
G007357	115	53	1036	19.6	1524	28.8	2226	42
G007358	127	47.5	1026	21.6	1508	31.8	2043	43
G007359	139	43	1016	23.6	1494	34.8	2064	48
G007360	152	39	1008	25.8	1482	38.0	2028	52
G007361	305	21.2	1099	51.9	1617	76.3	2226	105

Hole Ø D - 10 mm. Rod Ø d - 5 mm Wire Section - 2 mm x 1.5 mm								
System Code	Free Length	Spring Rate N	Max. Reflection 17%		Max. Reflection 20%		Deflection Solid	
	mm	mm	N	mm	N	mm	N	mm
G0007363	32	374	2037	5.4	2995	8	4118	11
G0007364	38	346	2235	6.5	3287	9.5	4498	13
G0007365	44	244	1825	7.5	2684	11	3904	16
G0007366	51	208	1799	8.7	2646	12.8	3735	18
G0007367	64	161	1752	10.9	2576	16	3703	23
G0007368	76	131	1690	12.9	2485	19	3401	26
G0007369	89	111	1672	15.1	2459	22.3	3426	31
G0007370	102	96.3	1670	17.3	2456	25.5	3467	36
G0007371	115	85.7	1675	19.6	2464	28.8	3514	41
G0007372	127	76.3	1647	21.6	2423	31.8	3586	47

G0007374	152	63.5	1641	25.8	2413	38	3429	54
G0007375	178	53.9	1631	30.3	2399	44.5	3396	63
G0007376	203	47	1622	34.5	2385	50.8	3384	72
G0007377	305	30.9	1602	51.9	2356	76.3	3492	113

Hole Ø D - 32 mm. Rod Ø d - 16 mm Wire Section - 7.15 mm x 5.7 mm								
System Code	Free Length	Spring Rate N	Max. Reflection 20%		Max. Reflection 20%		Deflection Solid	
	mm	mm	N	mm	N	mm	N	mm
G0007378	38	528	3412	6.5	5018	9.5	6338	12
G0007379	44	424	3175	7.5	4668	11	6366	15
G0007380	51	353	3061	8.7	4501	12.8	6001	17
G0007381	64	269	2929	10.9	4307	16.0	5922	22
G0007382	76	219	2823	12.9	4152	19	5463	25

G0007383	89	180	2728	15.1	4012	22.3	5950	33
G0007383	102	155	2688	17.3	3953	25.5	5580	36
G0007385	115	140	2737	19.6	4025	28.8	5880	42
G0007386	127	124	2677	21.6	3937	31.8	5704	46
G0007387	152	102	2636	25.8	3876	38	5712	56
G0007388	178	88.2	2669	30.3	3925	44.5	5645	64
G0007389	203	76.0	2623	34.5	3857	50.8	5396	71
G0007390	254	60.8	2625	43.2	3861	63.5	5472	90
G0007391	305	49.0	2541	51.9	3736	76.3	5047	103

Hole Ø D - 40 mm. Rod Ø d - 20 mm Wire Section - 8.55 mm x 6.9 mm								
System Code	Free Length	Spring Rate N	Max. Reflection 20%		Max. Reflection 20%		Deflection Solid	
	mm	mm	N	mm	N	mm	N	mm
G0007004	51	628	5445	8.7	8007	12.8	10676	17
G0007392	64	487	5299	10.9	7792	16	11201	23
G0007393	76	379	4897	12.9	7201	19	10233	27
G0007394	89	321	4857	15.1	7142	22.3	9951	31
G0007395	102	281	4873	17.3	7166	25.5	10116	36
G0007396	115	245	4790	19.6	7044	28.8	9800	40
G0007397	127	221	4771	21.6	7017	31.8	9724	44
G0007397	139	202	4773	23.6	7020	34.8	10504	52
G0007399	152	168	4341	25.8	6384	38	9408	56
G0007400	178	148	4478	30.3	6586	44.5	9028	61

G0007401	203	132	4555	34.5	6699	50.8	9636	73
G0007402	254	107	4620	43.2	6795	63.5	9951	93
G0007403	305	87.8	4552	51.9	6695	76.3	9307	106

Hole Ø D - 50 mm. Rod Ø d - 25 mm Wire Section - 11.5 mm x 9.2 mm								
System Code	Free Length	Spring Rate N	Max. Reflection 20%		Max. Reflection 20%		Deflection Solid	
	mm	mm	N	mm	N	mm	N	mm
G0007404	64	709	7714	10.9	11344	16	14889	21
G0007405	76	572	7390	12.9	10868	19	14300	25
G0007406	89	475	7187	15.1	10569	22.3	13300	28
G0007407	102	405	7023	17.3	10328	25.5	13365	33
G0007408	115	352	6882	19.6	10120	28.8	13376	38

G0007409	127	316	6822	21.6	10033	31.8	13588	43
G0007409	139	289	6829	23.6	10043	34.8	13583	47
G0007411	152	239	6176	25.8	9082	38	12667	53
G0007412	178	216	6536	30.3	9612	44.5	12960	60
G0007413	203	187	6453	34.5	9490	50.8	13277	71

G0007414	254	153	6607	43.2	9716	63.5	13923	91
G0007415	305	127	6585	51.9	9684	76.3	13462	106



Vertical Toggle Clamps

50 kg clamping force (Type 101 A) with a horizontal base, open clamping arm and a length of 51 mm. Holding capacity: N F1 = 160 F2 = 490

System Code: A0018060

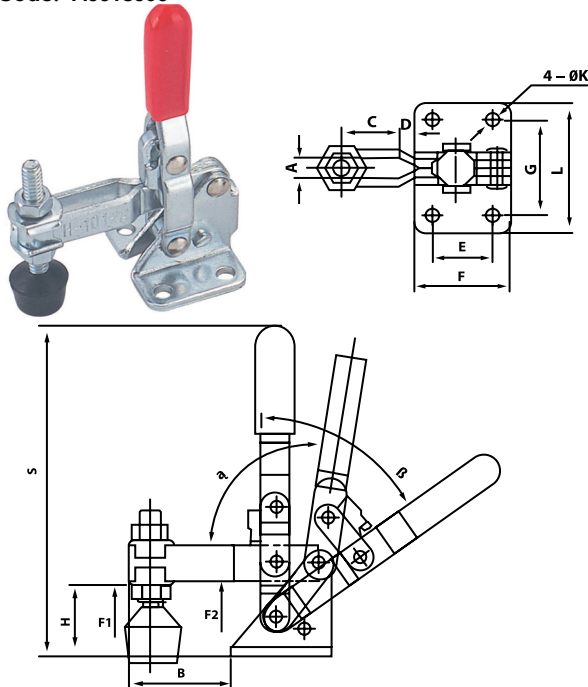

A	B	C	D	E	F	G	H	L	K	S	∞	β
5.5	26	17	4	16	25.4	24	16	34	4.5	77	100	56

115 kg clamping force (Type 102 B) with a horizontal base, open clamping arm and a length of 68 mm. Holding Capacity: N F1 = 399 F2 = 980

System Code: A0018057

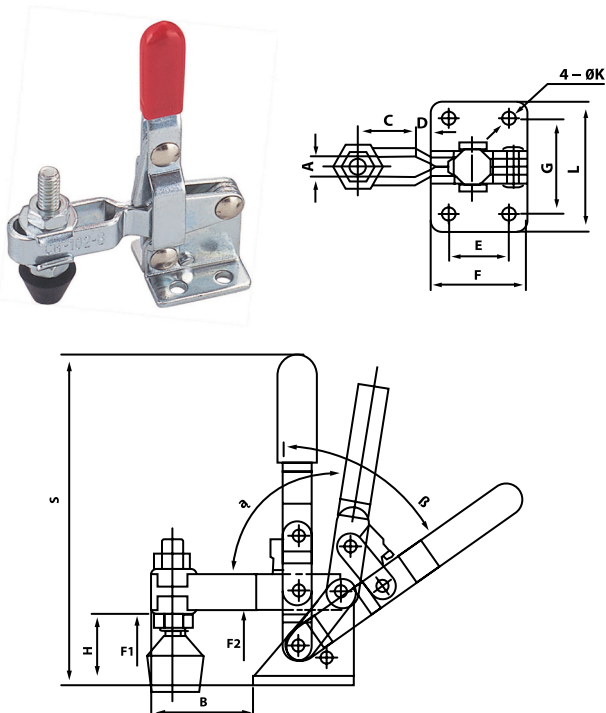

A	B	C	D	E	F	G	H	L	K	S	∞	β
6.5	39	24	9	14	29	18	19	28	5	94	90	65

Vertical Toggle Clamps

150 kg clamping force (Type 11421) with a horizontal base, open clamping arm and a length of 106 mm. Holding Capacity: N F1 = 672 F2 = 1470

System Code: A0018058

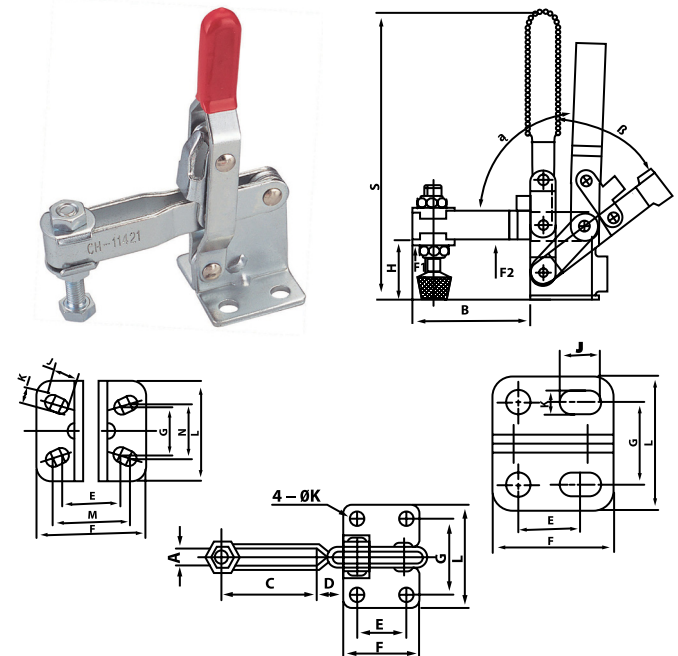

A	B	C	D	E	F	G	H	L	K	S	∞	β
8.5	63	35	20	24	43	33	38	50	8.5	139	94	53

340 kg clamping force (Type 12265) horizontal base, open clamping arm and a length of 144 mm. Holding capacity: N F1 = 807 F2 = 3332

System Code: A0018657

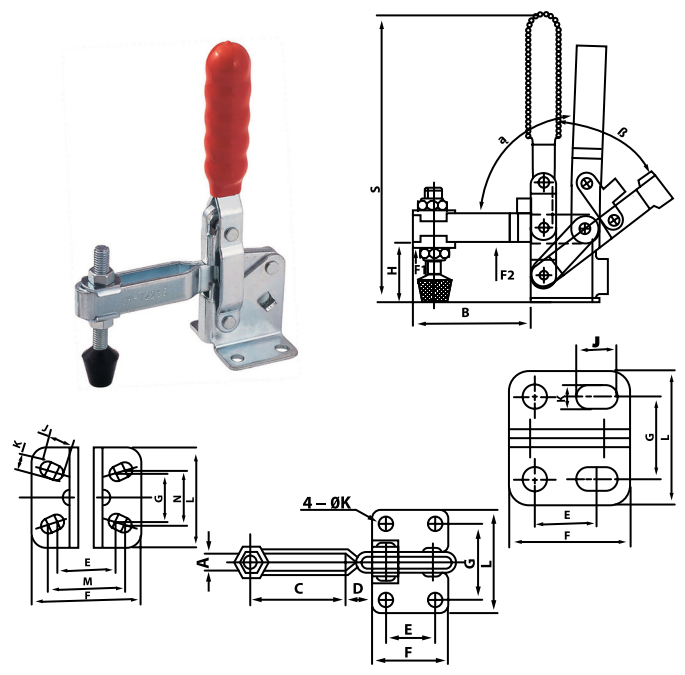

A	B	C	D	E	F	G	H	L	K	S	∞	β
10.5	85	62	11	32	50	45	44	64	8.5	201	105	58

Vertical Toggle Clamps

450 kg clamping force (Type 101H) with a horizontal base, open clamping arm and a length of 195 mm. Holding Capacity: N F1 = 1002 F2 = 4410

System Code: A0018059

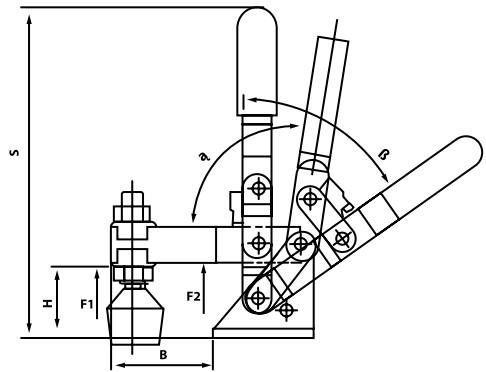
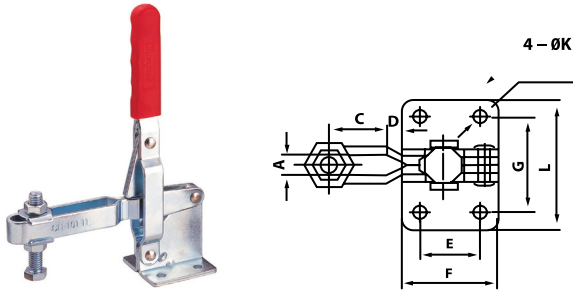

A	B	C	D	E	F	G	H	L	K	S	∞	β
17	128	102	15	40	70	43	60	70	9.5	270	101	63

Vertical Toggle Clamps



90 kg clamping force (Type 201 B) with a horizontal base, open clamping arm and a length 138 mm. Holding Capacity: N F1 = 320 F2 = 882

System Code: A0018653

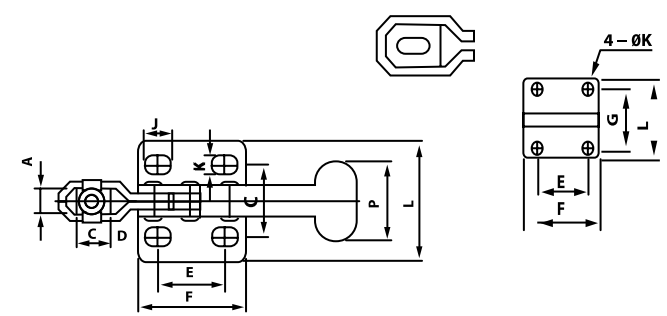
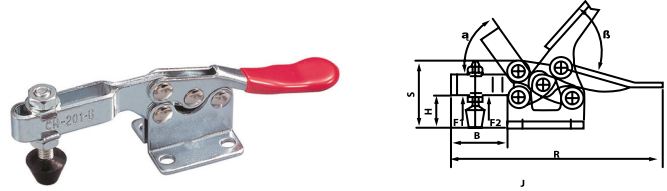

A	B	C	D	E	F	G	H	L	J	K	P	R	S	∞	β
6.5	56	35	15	26	36	22	25.5	36	6	5.5	20	141	39	85	60

Horizontal Toggle Clamps

27 kg clamping force (Type 201) with a horizontal base, open clamping arm and a length of 79 mm. Holding Capacity: N F1 = 1

System Code: A0018652

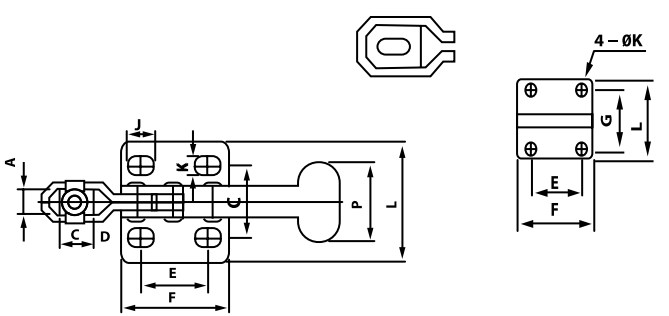
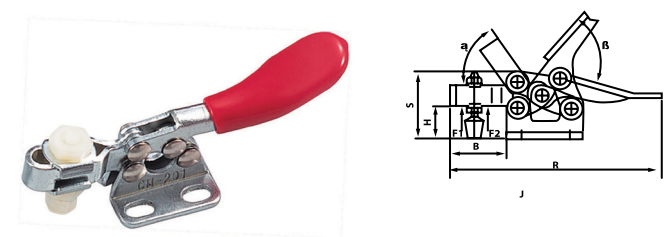

A	B	C	D	E	F	G	H	L	J	K	P	R	S	∞	β
4.5	20	10	8	14	24	16	8	24	7	20	10	8	14	24	16

Horizontal Toggle Clamps

100 kg clamping force (Type 201 C) horizontal base, open clamping arm and a length of 146 mm. Holding Capacity: N F1 = 164 F2 = 264

System Code: A0018048

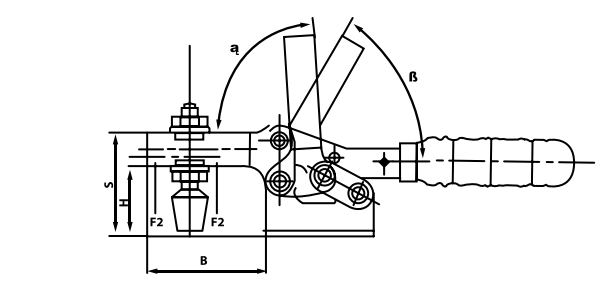
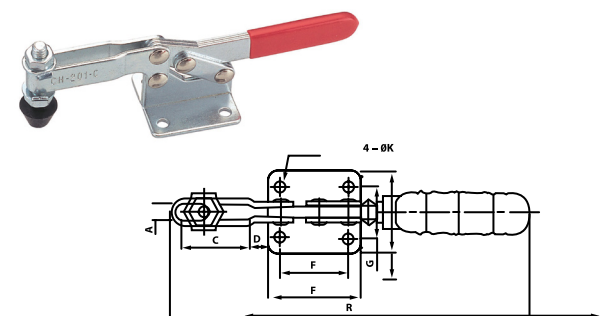

A	B	C	D	E	F	G	H	L	K	S	∞	β
8.5	63	35	20	24	43	33	38	50	8.5	139	94	53

MACHINE TOOLING



Horizontal Toggle Clamps

227 kg clamping force (Type 225 D) with a horizontal base, open clamping arm and a length of 168 mm. Holding Capacity: N F1 = 1200 F2 = 2224

System Code: A0018049

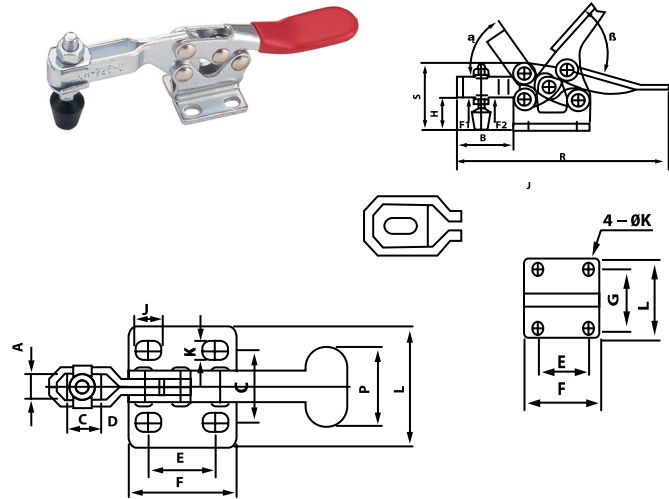

A	B	C	D	E	F	G	H
8.5	75	32	30	23	38	24	35.5

L	J	K	P	R	S	∞	β
35	11	6.5	26	168	48	90	65

Horizontal Toggle Clamps

280 kg clamping force (Type 25382) with a horizontal base, open clamping arm and length of 260 mm. Holding capacity N F2 = 2774

System Code: A0018051

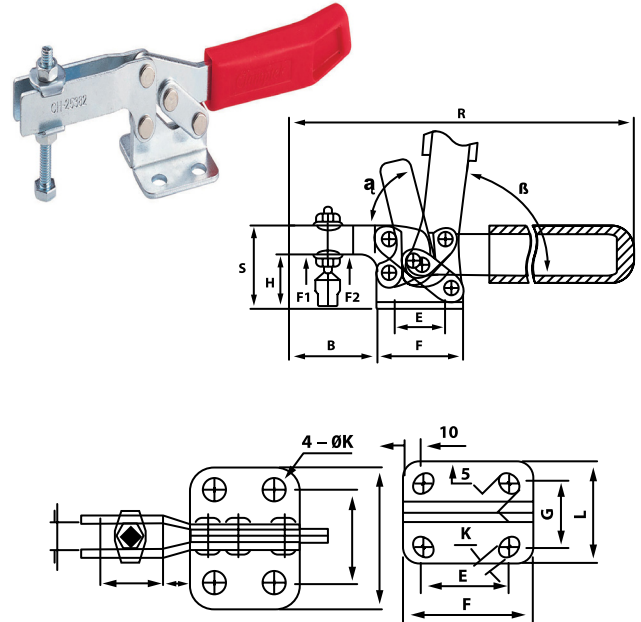

A	B	C	D	E	F	G	H	L	K	R	S	∞	β
8.5	85	56	17	30	50	37	36.5	57	10.5	248	56.5	80	80

Horizontal Toggle Clamps

250 kg clamping force (Type 22165H) with a horizontal base, open clamping arm and a length of 185 mm. Holding Capacity N: F1 = 1431 F2 = 2450

System Code: A0018050

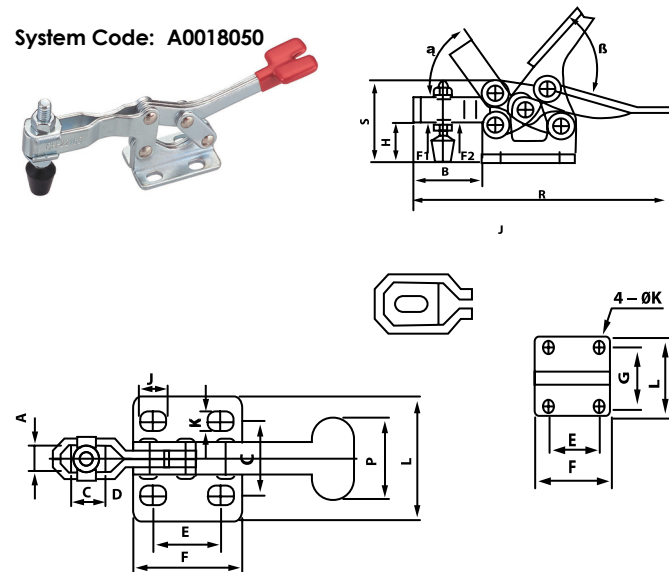

A	B	C	D	E	F	G	H
8.5	71.5	32	32	28	56	22	33

L	J	K	P	R	S	∞	β
35	10	6.5	30	185	50	96	88

Push/Pull Toggle Clamps

45 kg clamping force (Type 301 AM) with a horizontal base, a plunger stroke of 16.7 mm and a length of 63 mm. Holding capacity: N F1 = 441 F2 = 38

System Code: A0018662

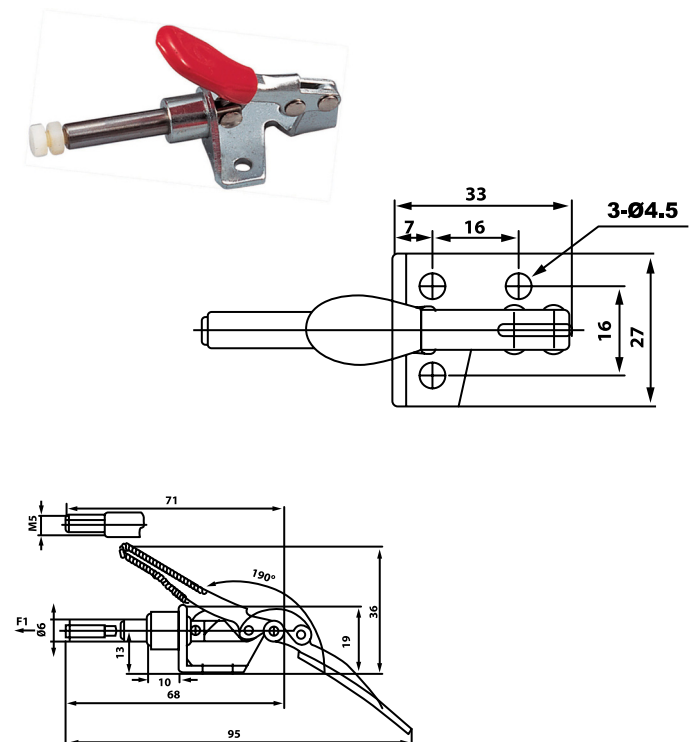



Push/Pull Toggle Clamps

180 kg clamping force (Type 36020 AM) with a horizontal base, plunger stroke of 30 mm and a length of 91.5 mm. Holding Capacity N: F1 = 1764 F2 = 387

System Code: A0018660

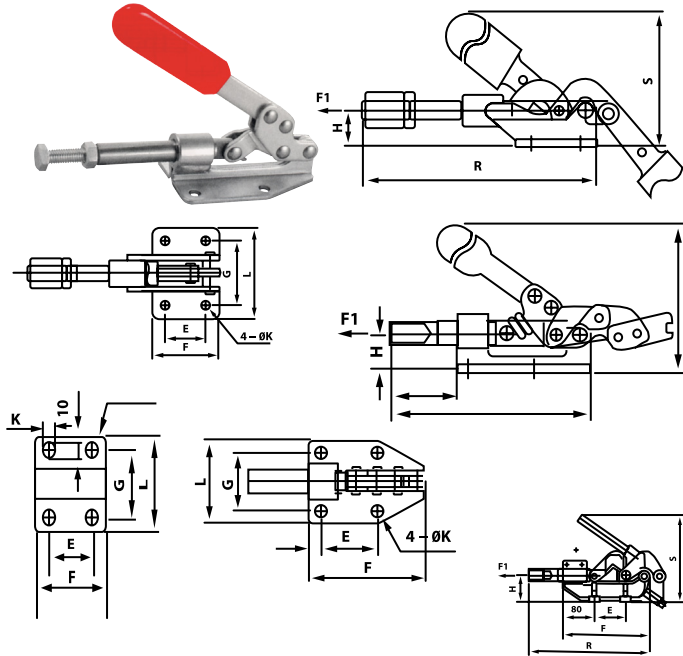

E	F	G	H	L	K	R	S
40	83	20	20	50	6.5	126	103

Push/Pull Toggle Clamps

386kg clamping force (Type 304 EM) with a horizontal base, a plunger stroke of 32 mm and a length of 158 mm. Holding Capacity: N F1 = 2224 F2 = 337

System Code: A0018656

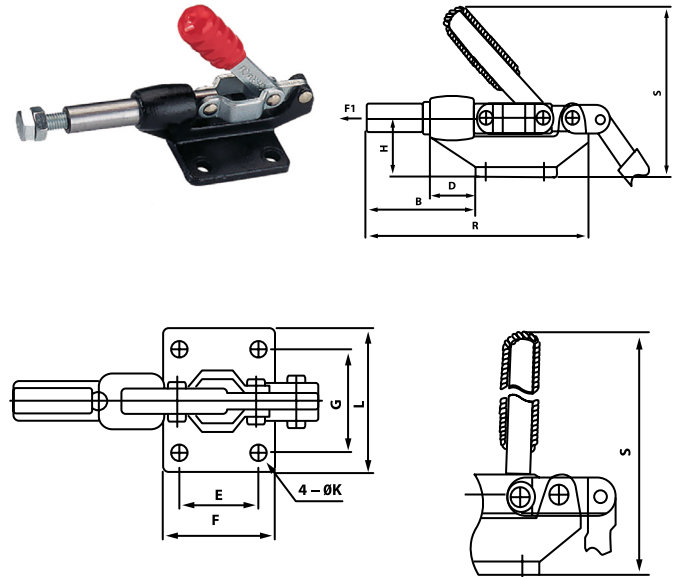

B	D	E	F	G	H	L	ød	K	R	S
52	22	35	52	41	35	57	6.5	6.5	126	75

Push/Pull Toggle Clamps

227 kg clamping force (Type 304 CM) with a horizontal base, plunger stroke of 32 mm and a length of 125 mm. Holding Capacity: N F1 = 2224 F2 = 337

System Code: A0018661

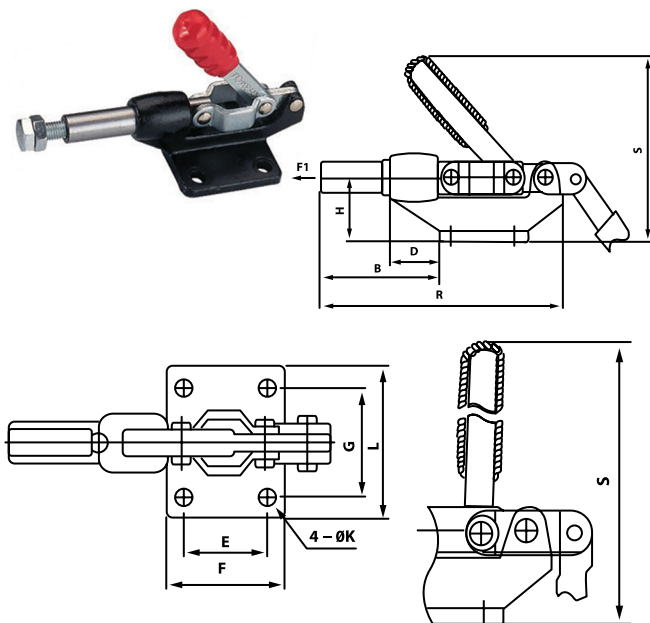

B	D	E	F	G	H	L	ød	K	R	S
52	22	35	52	41	25	57	6.5	6.5	126	75

Latch Toggle Clamps

160 kg clamping force (Type 40323) with a horizontal base & a base length of 26 mm. Holding Capacity: N F1 = 1600 F2 = 74

System Code: A0018654

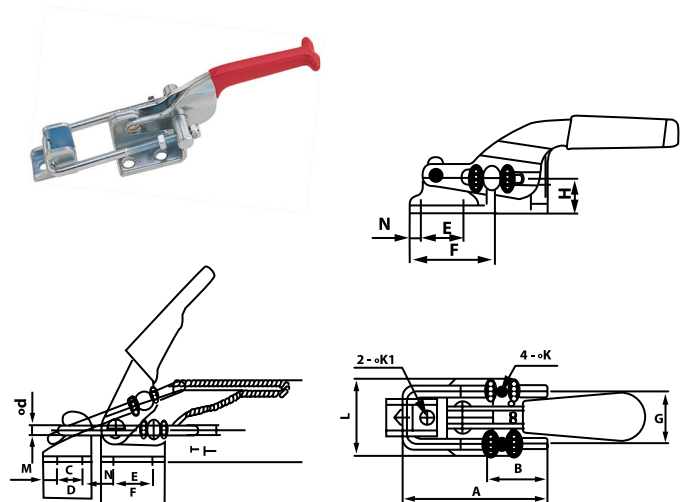

A	B	C	D	E	F	G	L	M	N	K	K1	ød	H	T	S
57	24	10	20	16	26	19	29	6	5	4.5	4	12	M4	M4	30



Latch Toggle Clamps

320 kg clamping force (Type 431) with a horizontal base & a base length of 40 mm.
Holding Capacity: N F1 = 3116 F2 = 234

System Code: A0018655

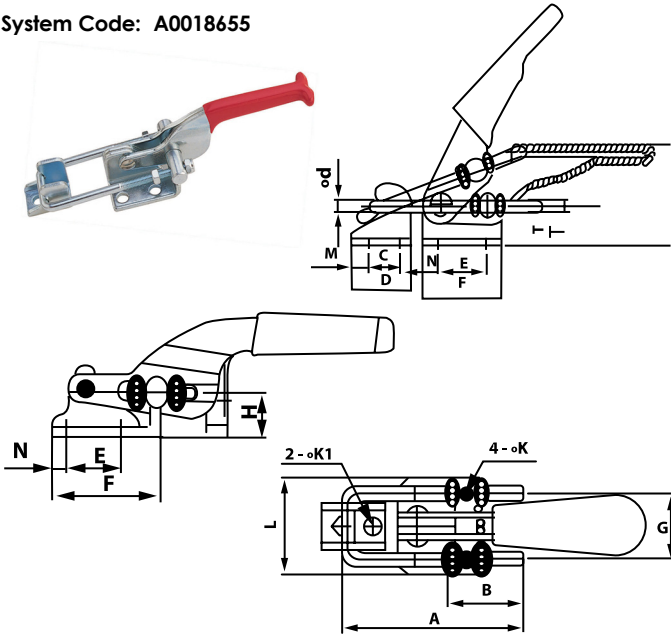

A	B	C	D	E	F	G	L
92	40	12	26	19	40	32	45

M	N	K	K1	ø _d	H	T	S
7	6.5	6.5	6.5	6	16	M6	51

Latch Toggle Clamps

3400 kg clamping force (Type 40380) with a horizontal base & a base length of 86 mm.
Holding Capacity: N F1 = 33320 F2 = 1480

System Code A0018658

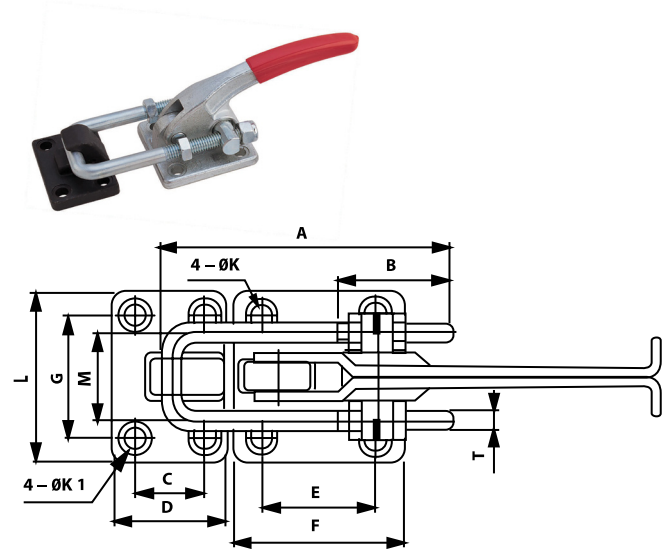

A	B	C	D	E	F	G	L
147	74	35	57	57	85	57	79

M	N	K	K1	ø _d	R	T	S
54	28	10.5	10.5	12	M12	185	83

Kipp Knurled Knobs

Anthracite grey thermoplastic bush and thread bolt; blue Chromated steel. Also available in stainless steel.

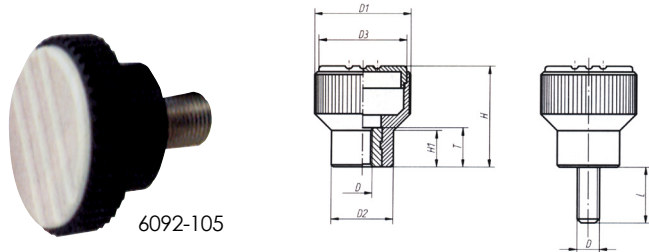

6092-105

Internal Threads							
System Code	Thread Size	D1	D2	D3	H	H1	T
6092-105	M5	21	14	12	22	8	10
6092-106	M6	21	14	19	22	8	10
6092-208	M8	24	18	23	26	9.5	14
6092-310	M10	34	22	31	36	13	14

External Threads							
System Code	Thread Size	D1	D2	D3	H	H1	T
6092-105X15	M5	21	14	19	22	8	15
6092-106X15	M6	21	14	19	22	8	15
6092-208X20	M8	26	18	23	26	9.5	20
6092-208X25	M8	26	18	23	26	9.5	25
6092-208X20	M10	34	22	31	36	13	20
6092X310X30	M10	34	22	31	36	13	30
6092X310X40	M10	34	22	31	36	13	40

Kipp Cross Knobs

Black duroplastic bush: galvanised steel (DIN 6335).

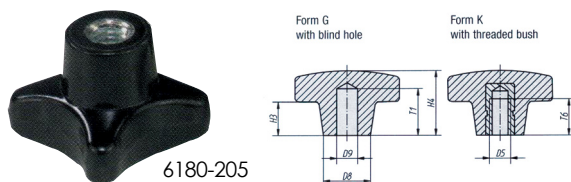

6180-205

Kipp Cross Knobs					
System Code	D5	T6	Outside Ø	Small Ø	Height mm
6180-205	M5	9.5	25	12	16
6180-206	M6	12	32	14	20
6180-208	M8	14	40	18	25
6180-210	M10	18	50	22	32
6180-212	M12	22	63	26	40

Kipp Star Grips with Internal Threads

Black thermoplastic with steel bush.



DIN 6336

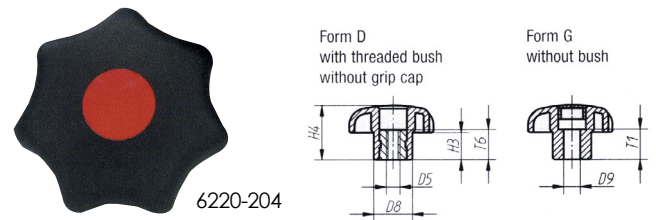

6220-204

Kipp Star Grips with Internal Threads						
System Code	D5	D8	Outside Ø	H3	H4	T6
6220-204	M4	12	25	8	16	10
6220-205	M5	12	25	8	16	10
6220-2051	M5	14	32	10	20	10
6220-206	M6	14	32	10	20	10
6220-208	M8	18	40	13	25	14
6220-2081	M8	22	50	17	32	14
6220-210	M10	22	50	17	32	14
6220-2102	M10	26	63	21	40	14
6220-212	M12	26	63	21	40	18
6220-216	M16	26	63	21	40	18

Kipp Cross Knobs

Black duroplastic bush galvanised steel (DIN 6335).



Kipp Cross Knobs					
System Code	D6	Outside Ø	Small Ø	Overall Length	L
6220-405X15	M5	25	12	16	15
6220-405X20	M5	25	12	16	20
6220-405X25	M5	25	12	16	25
6220-406X10	M6	20	14	20	10
6220-406X15	M6	20	14	20	15
6220-406X20	M6	20	14	20	20
6220-406X25	M6	20	14	20	25
6220-406X40	M6	20	14	20	40
6220-4061X25	M6	32	14	20	25
6220-408X15	M8	32	14	20	15
6220-408X25	M8	32	14	20	25
6220-408X30	M8	32	14	20	30
6220-408X40	M8	32	14	20	40
6220-4081X25	M8	40	18	25	25
6220-4081X30	M8	40	18	25	30
6220-410X30	M10	40	18	25	30
6220-410X35	M10	40	18	25	35
6220-410X60	M10	40	18	25	60
6220-4101X30	M10	50	22	32	30
6220-412X35	M12	50	22	32	35
6220-412X40	M12	50	22	32	40
6220-412X60	M12	50	22	32	60
6220-4121X60	M12	63	26	40	60
6220-416X45	M16	63	26	40	45

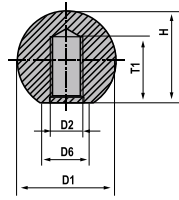

Black thermoplastic and pressed thread
(DIN 319, Form C)

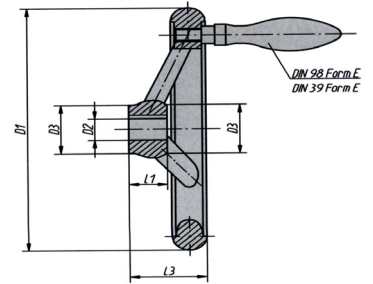

(DIN 950)

Kipp Ball Knobs					
System Code	D2	D1	D6	H	T1
6250-11604	M4	16	8	15	7.5
6250-11605	M5	16	8	15	7.5
6250-12006	M6	20	12	18	10.5
6250-12506	M6	25	15	23	13.5
6250-12508	M8	25	15	23	13.5
6250-13208	M8	32	18	29	16
6250-13210	M10	32	18	29	16
6250-14010	M10	40	20	37.5	23
6250-14012	M12	40	20	37.5	23
6250-15012	M12	50	22	48	31

Kipp Aluminium Handwheels							
System Code	D	D2	D3	L1	L3	Keyway Width	Handle Thread
						mm	
6273-0100X10	100	10	26	17	33	3	M6
6273-0100X12	100	12	26	17	33	4	M6
6273-0125X12	125	14	28	18	36	4	M8
6273-0160X14	160	16	32	20	40	5	M10
6273-0160X16	160	18	32	20	40	5	M10
6273-0200X18	200	22	38	24	45	6	M10
6273-0250X22	250	22	45	28	50	6	M12

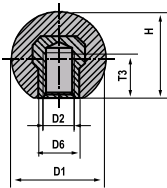

Black Durooplastic with Threaded Steel Bush
DIN 319, Form E



DIN 98 Form E

Kipp Ball Knobs					
Stock Code	D2	D1	D6	H	T3
6250-21604	M4	16	8	15	7.5
6250-22005	M5	20	12	18	10.5
6250-22006	M6	20	12	18	10.5
6250-22506	M6	25	15	23	13.5
6250-22508	M8	25	15	23	13.5
6250-23208	M8	32	18	29	16
6250-23210	M10	32	18	29	16
6250-24010	M10	40	20	37.5	23
6250-24012	M12	40	20	37.5	23
6250-25012	M12	50	22	48	31

Kipp Revolving Machine Handles				
System Code	Mounting Thread	To Suit Wheel	Ø	Handle Length
			mm	mm
6308-0616055	M6	100	16	49
6308-0820067	M8	125	20	61
6308-1025083	M10	160/200	25	75
6308-1232105	M12	250	32	95

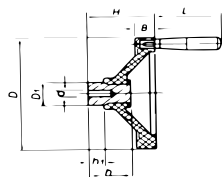

Black duroplastic with threaded steel bush and revolving taper grip
DIN 319, Form E



The handles are die-cast Zinc and the steel parts are Class 5.8
DIN 98 Form E

Disc Handwheels								
System Code	D	B	D1	d	H	h	h1	L
8313-06X100	100	14	24	6	41	26	10	48
8313-08X120	120	17	28	8	48	30	12	64
8313-10X160	160	22	36	10	59	35	15	74
8313-10X150	190	25	40	10	77	45	15	74

Kipp Internal Thread Clamp Levers					
System Code	Mounting Thread	Overall Length	Overall Height	Large Ø	Small Ø
		mm	mm		
6450-1051	M5	47	31	14	10
6450-1061	M6	47	31	14	10
6450-2081	M8	74.5	42.5	19	13.5
6450-3081	M8	91	54.5	22	16
6450-3101	M10	91	54.5	22	16
6450-4101	M10	109	63	27.5	19
6450-4121	M12	109	63	27.5	19
6450-5161	M16	126	73	32	23



G0009261

The handles are die-cast zinc and the steel parts are class 5.8.

Kipp External Thread Clamp Levers					
System Code	Mounting Thread	Overall Length	Overall Height	Large Ø	Small Ø
		mm	mm		
G0009261	M6	20	47	13	10
G0009262	M6	30	47	13	10
G0009263	M6	40	47	13	10
G0009264	M6	50	47	13	10
G0009265	M8	20	74.5	18.5	13.5
G0009266	M8	30	74.5	18.5	13.5
G0009267	M8	40	74.5	18.5	13.5
G0009268	M8	60	74.5	18.5	13.5
G0009269	M10	30	91	21	16
G0009270	M10	45	91	21	16
A0032500	M10	50	91	21	16
G0009271	M10	60	91	21	16
6460-4101X35	M10	35	109	27	19
6460-4101X40	M10	40	109	27	19
6460-4101X50	M10	50	109	27	19
6460-4101X60	M10	60	109	27	19
G0009272	M12	30	109	27	19
6460-4121X40	M12	60	109	27	19



6600-1041

The handles are die-cast zinc and the steel parts are class 5.8.

Kipp Internal Thread Clamp Levers					
System Code	Mounting Thread	Overall Length	Overall Height	Large Ø	Small Ø
		mm	mm		
6600-1041	M4	47	30	13	10
6600-1051	M5	47	30	13	10
G0008747	M6	47	30	13	10
G0009278	M8	75	41.5	18	13.5
G0008748	M10	91.5	53.5	21.5	16
G0008749	M12	109	61	25.5	19
G0009279	M12	126	72	30	23
G0009280	M16	126	72	30	23



G0009281

The handles are glass fibre reinforced with a toothed wheel made from die-cast zinc. The steel parts are class 5.8.

Kipp External Thread Clamp Levers						
System Code	Mounting Thread	Thread Length	Overall Length	Overall Height	Large Ø	Small Ø
		mm	mm	mm		
G0009281	M5	20	47	30	13	10
6610-1051X30	M5	30	47	30	13	10
6610-1051X40	M5	40	47	30	13	10
G0009282	M6	20	47	30	13	10
G0009283	M6	30	47	30	13	10
6610-1061X40	M6	40	47	30	13	10
6610-2081X20	M8	20	75	41.5	18	13.5
G0009284	M8	30	75	41.5	18	13.5
6610-2081X40	M8	40	91.5	41.5	18	13.5
G0009285	M10	30	91.5	53.5	21.5	16
6610-3101X40	M10	40	91.5	53.5	21.5	16
G0009286	M10	50	91.5	53.5	21.5	16
6610-4121X30	M12	30	109	61	25.5	19
6610-4121X50	M12	50	109	61	25.5	19
G0009287	M12	60	109	61	25.5	19



G0008791

Material Hardened and Ground Tool Steel

DIN 6321, Form A

Kipp Support Bolts					
System Code	Head Ø	Body Ø	Head Length	Champhered Length	Overall Length
			mm	mm	mm
G0008791	M5	47	30	10	40
2020-110	M5	47	30	10	40
2020-116	M5	47	30	10	40
2020-125	M5	47	30	10	40



2020-206

DIN 6321, Form B

Kipp Support Bolts					
System Code	Head Ø	Body Ø	Head Length	Champhered Length	Overall Length
			mm	mm	mm
G0008792	6	4	7	4	13
2020-208	8	6	10	6	19
2020-210	10	6	10	6	19
2020-212	12	6	10	6	19
2020-216	16	8	13	8	25
2020-220	20	12	15	9	33



Drill Bushes

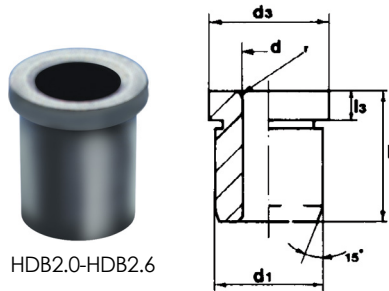

HDB2.0-HDB2.6

Short

Press Fitted & Through Hardened Headed Drill Bushes (DIN 172A)					
System Code	Bore d F7	d n6	d	L	L
HDB2.0-HDB2.6	2.0-2.6	5	8	6	2
HDB2.7-HDB3.3	2.7-3.3	6	10	8	2
HDB3.4-HDB4	3.4-4	7	11	8	2
HDB4.1-HDB5	4.1-5	8	12	8	2
HDB5.1-HDB6	5.1-6	10	14	10	3
HDB6.1-HDB8	6.1-8	12	16	10	3
HDB8.1-HDB10	8.1-10	15	19	12	4
HDB10.1-HDB12	10.1-12	18	22	12	4
HDB12.1-HDB15	12.1-15	22	26	16	4
HDB15.1-HDB18	15.1-18	26	30	16	4
HDB18.1-HDB22	18.1-22	30	35	20	5
HDB22.1-HDB26	22.1-26	35	40	20	5
HDB26.1-HDB30	26.1-30	42	47	20	5
HDB30.1-HDB35	30.1-35	48	55	25	5
HDB35.1-HDB42	35.1-42	55	62	25	5
HDB42.1-HDB48	42.1-48	63	69	30	6
HDB48.1-HDB50	48.1-50	70	77	30	6

NOTE: Bushes with a Ø range of 2 mm to 20 mm are available in 0.1 mm increments. Bushes with a Ø range 21 mm to 50 mm are available in 1.0 mm increments.

Long

Press Fitted & Through Hardened Headed Drill Bushes (DIN 172A)					
System Code	Bore d F7	d n6	d	L	L
HDBL2.0-HDBL2.6	2.0-2.6	5	8	9	2
HDBL2.7-HDBL3.3	2.7-3.3	6	10	12	3
HDBL3.4-HDBL4	3.4-4	7	11	12	3
HDBL4.1-HDBL5	4.1-5	8	12	12	3
HDBL5.1-HDBL6	5.1-6	10	14	16	3
HDBL6.1-HDBL8	6.1-8	12	16	16	3
HDBL8.1-HDBL10	8.1-10	15	19	20	4
HDBL10.1-HDBL12	10.1-12	18	22	20	4
HDBL12.1-HDBL15	12.1-15	22	26	28	4
HDBL15.1-HDBL18	15.1-18	26	30	28	4
HDBL18.1-HDBL22	18.1-22	30	35	36	5
HDBL22.1-HDBL26	22.1-26	35	40	36	5
HDBL26.1-HDBL30	26.1-30	42	47	36	5
HDBL30.1-HDBL35	30.1-35	48	55	45	5
HDBL35.1-HDBL42	35.1-42	55	62	45	5
HDBL42.1-HDBL48	42.1-48	63	69	56	6

NOTE: Bushes with a Ø range of 2 mm to 20 mm are available in 0.1 mm increments. Bushes with a Ø range 21 mm to 50 mm are available in 1.0 mm increments.

Drill Bushes

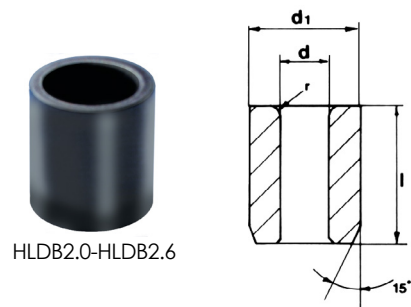

HLDB2.0-HLDB2.6

Short

Press Fitted & Through Hardened Headed Drill Bushes (DIN 179A)				
System Code	Bore d F7	d n6	d ₃	L
HLDB2.0-HLDB2.6	2.0-2.6	5	6	1
HLDB2.7-HLDB3.3	2.7-3.3	6	8	1
HLDB3.4-HLDB4	3.4-4	7	8	1
HLDB4.1-HLDB5	4.1-5	8	8	1
HLDB5.1-HLDB6	5.1-6	10	10	1
HLDB6.1-HLDB8	6.1-8	12	10	1
HLDB8.1-HLDB10	8.1-10	15	12	1.5
HLDB10.1-HLDB12	10.1-12	18	12	1.5
HLDB12.1-HLDB15	12.1-15	22	16	1.5
HLDB15.1-HLDB18	15.1-18	26	16	1.5
HLDB18.1-HLDB22	18.1-22	30	20	1.5
HLDB22.1-HLDB26	22.1-26	35	20	1.5
HLDB26.1-HLDB30	26.1-30	42	20	1.5
HLDB30.1-HLDB35	0.1-35	48	25	2
HLDB35.1-HLDB42	35.1-42	55	25	2
HLDB42.1-HLDB48	42.1-48	63	30	2
HLDB48.1-HLDB55	48.1-55	70	30	2

NOTE: Bushes with a Ø range of 2 mm to 20 mm are available in 0.1 mm increments. Bushes with a Ø range 21 mm to 50 mm are available in 1.0 mm increments.

Long

Press Fitted & Through Hardened Headed Drill Bushes (DIN 179A)				
System Code	Bore d F7	d	L	L
HLDBL2.0-HLDBL2.6	2.0-2.6	5	9	1
HLDBL2.7-HLDBL3.3	2.7-3.3	6	12	1
HLDBL3.4-HLDBL4	3.4-4	7	12	1
HLDBL4.1-HLDBL5	4.1-5	8	16	1
HLDBL5.1-HLDBL6	5.1-6	10	16	1
HLDBL6.1-HLDBL8	6.1-8	12	16	1
HLDBL8.1-HLDBL10	8.1-10	15	20	1.5
HLDBL10.1-HLDBL12	10.1-12	18	20	1.5
HLDBL12.1-HLDBL15	12.1-15	22	28	1.5
HLDBL15.1-HLDBL18	15.1-18	26	28	1.5
HLDBL18.1-HLDBL22	18.1-22	30	36	1.5
HLDBL22.1-HLDBL26	22.1-26	35	36	1.5
HLDBL26.1-HLDBL30	26.1-30	42	36	1.5
HLDBL30.1-HLDBL35	30.1-35	48	45	2
HLDBL35.1-HLDBL42	35.1-42	55	45	2
HLDBL42.1-HLDBL48	42.1-48	62	56	2
HLDBL48.1-HLDBL55	48.1-55	70	56	2

NOTE: Bushes with a Ø range of 2 mm to 20 mm are available in 0.1 mm increments. Bushes with a Ø range 21 mm to 50 mm are available in 1.0 mm increments.



Lamps

Anti-explosion, dust-proof and waterproof. The lamp has a built-in transformer.

2 Types of lamps Available
220V Input and 24V Input.
Globes: 12V, 55W and 24V,
70W Respectively.



G00082372

Quartz Halogen Machine Lamps						
System Code	Arm	Volt	Bulb Watt	Base Arm Length	Top Arm Length	Lamp Ø
				mm	mm	mm
G0002372	Short	220	12V 55W	95	-	125
A0031862	Medium	220	12V 55W	185	260	125
A0031861	Long	220	12V 55W	400	430	125
G0002373	Short	24	24V 70W	95	-	125
G0002369	Medium	24	24V 70W	185	260	125
QLL24	Long	24	24V 70W	400	430	125

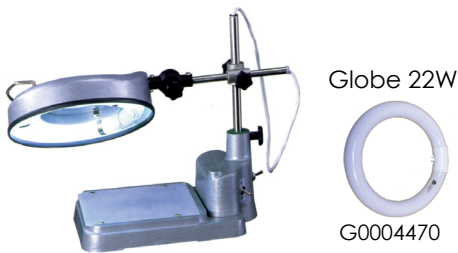

Globe 22W



G0004470

The lamp is mounted onto an inspection table. The lamp head is fitted with a magnifying lens and a circular fluorescent tube.

Table Mounted Inspection Lamps					
System Code	Volt	Tube Watt	Magnification	Base Length	Height
				mm	mm
G0004470	220	22W	5x	320	340



Globe 22W



G0002335

The lamp head fitted with a magnifying lens and a circular fluorescent tube.

Inspection Lamps							
System Code	Arm	Volt	Tube Watt	Magnification	Base Arm Length	Top Arm Length	Head Ø
					mm	mm	mm
G0002335	Medium	220	22W	5x	265	260	235
A0031853	Long	220	22W	5x	400	430	235
ILS#	Spring	220	22W	5x	400	430	235

Chucks



A0018822

Key Type Drill Chucks					
System Code	Capacity	Body Ø	Length	Mounting	Key
		mm	mm		
A0018822	13	40	60	B16	S2
DC13B16	13	42	60	B16	T5
G0001384	13	42.5	72.5	1/2 x 20	S2
G0001536	13	53.0	86.0	1/2 x 20	S3
G0002364	13	54	70	B16	T8
H0001670	16	58	75	B18	T8



G00021180

Key Type Drill Chucks - Light-Duty					
System Code	Capacity	Body Ø	Length	Mounting	Key
		mm	mm		
G0002180	1-10	33	60	3/8 x 24	KS10
PLDDC101/2x20	1-10	33	60	1/2 x 20	KS10
G0002182	1.5-13	42.5	74	3/8 x 24	KS2
G0002181	1.5-13	42.5	74	1/2 x 20	KS2

Key Type Drill Chucks - Medium-Duty					
System Code	Capacity	Body Ø	Length	Mounting	Key
		mm	mm		
G0002191	0-6	30	52	B10	KS1
G0002193	0-6	30	52	J1	KS1
PMDDC63/8x24	0-6	30	52	3/8 x 24	KS1
PMDDC83/8x24	0-8	30	52	3/8 x 24	KS1
PMDDC81/2x20	0-8	30	52	1/2 x 20	KS1
G0002185	0-10	36.5	60	B12	KS2
G0002184	0-10	36.5	60	3/8 x 24	KS2
G0002183	0-10	36.5	60	1/2 x 20	KS2
G0002123	1.5-13	42.7	74	B16	KS2
G0002123	1.5-13	42.7	74	J6	KS2
G0002186	1.5-13	42.7	74	3/8 x 24	KS2
G0002122	1.5-13	42.7	74	1/2 x 20	KS2
G0002124	3-16	51	89	B16	KS3
G0002189	3-16	51	89	B18	KS3
G0002190	3-16	51	89	J6	KS3
G0002188	3-16	51	89	5/8 x 16	KS3
PMDDC16M18	3-16	51	89	M18	KS3

Key Type Drill Chucks - Heavy-Duty					
System Code	Capacity	Body Ø	Length	Mounting	Key
		mm	mm		
G0002162	0-8	36.5	60	B12	KS2
G0002153	0-10	42.7	74	B16	KS2
PHDDC10J2	0-10	42.7	74	J2	KS2
G0002116	0-13	51	78	B16	KS3
G0002154	0-13	51	78	J6	KS3
PHDDC135/8x16	0-13	51	78	5/8 x 16	KS3
G0002117	1-16	60	100	B18	KS3
G0002157	1-16	60	100	J6	KS3
G0002156	1-16	60	100	J3	KS3

Chucks

Key Type Drill Chucks - Heavy-Duty					
System Code	Capacity	Body Ø	Length	Mounting	Key
		mm	mm		
G0002155	1-16	60	100	5/8 x 16	KS3
G0002159 G0002160	5-20 5-20	60	111	B22 J3	KS3 KS3
G0002161	5-26	75	139	B24	K20



A0018822

Chucks



G0008312

Integral Shank Keyless Drill Chucks				
System Code	Capacity	Shank	Body Ø	Length from Gauge Line
			mm	mm
G0008312	0.2-13	R8	48	81
G0008308	0.2-13	BT40	48	90
G0008311	0.2-13	ISO40	48	90
G0008309	0.2-13	BT50	54	70
G0008310	0.2-13	DIN40	48	80

Arbors



A0010752

Keyless Drill Chucks					
System Code	Capacity	Body Ø	Length	Total Indicated Run Out	Key
		mm	mm		
A0018822 A0018823	1-13 3-16	49 54	100 110	0.06 0.07	B16 B16
G0002220 G0002365	1-13 1-16	48 55	90 100	- -	B16 B16



G0002173

Hardened & Ground Straight Shank Drill Chuck Arbors				
System Code	Shank	Chuck Mounting Taper	Shank Length	Overall Length
			mm	mm
A0010752 A0010751 A0010753	10 12 16	B16 B16 B16	45 45 50	81 90 90

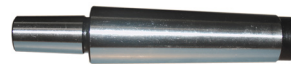

A0010997

Keyless Drill Chucks				
System Code	Capacity	Body Ø	Length	Mounting
		mm	mm	
G0002173 G0002174	0-6 0-6	34 34	68 68	B10 B12
G0002176 G0002177 G0002175	0-8 0-8 0-8	34 34 34	68 68 68	B12 J1 3/8 x 24
G0002165 G0002164 G0002163	1-10 1-10 1-10	35.5 35.5 35.5	81 81 81	B12 3/8 x 24 1/2 x 20
G0002121	1-10HD	40.5	89	B16
G0002118 G0002168 G0002167 G0002166	1-13 1-13 1-13 1-13	43 43 43 43	98 98 98 98	B16 J6 3/8 x 24 1/2 x 20
G0002178 G0002179	0-13HD 0-13HD	48.5 48.5	106 106	B16 J6
G0002119 G0002120 G0002172 G0002171 G0002169 G0002170	3-16 3-16 3-16 3-16 3-16 3-16	51 51 51 51 51 51	109 109 109 109 109 109	B16 B18 J6 J3 1/2 x 20 5/8 x 16

Hardened & Ground Morse Taper Drill Chuck Arbors with Draw Threads				
System Code	Shank	Chuck Mounting Taper	Shank Length	Overall Length
			mm	mm
A0010977 A0034510	MT2 MT3	B16 B16	M10 M12	101 108



G0008466

Hardened & Ground BT Drill Chuck Arbors			
System Code	Shank	Length Gauge Line to Front	Mounting Tapper
		mm	mm
G0008466 G0008467 G0008468	BT40 BT40 BT40	45 45 45	B12 B16 B18

Chucks



G0002133

For Taper Bores (DIN 238 & Jacobs)

Hardened & Ground Drill Chuck Arbors			
System Code	Machine Mounting Taper	Chuck Mounting Taper	Overall Length
			mm
G0002133 G0002134	B10 B10	1 2	84 101
G0010749 A0031960 A0031961	B12 B12 B12	1 2 3	90 105 124
G0002107 G0002108 G0001270 G0002110	B16 B16 B16 B16	1 2 3 4	97 112 131 156
G0002172 G0002112 G0002113	B18 B18 B18	2 3 4	120 139 164
G0002138 G0002114 G0002139	B22 B22 B22	2 3 4	128 147 164
G0002115 G0002140	B24 B24	3 4	157 182
G0002141 G0002142	J3 J3	2 3	114 133
G0002143 G0000964	J6 J6	2 3	108 127
G0001449 M20XMT4	M20 M20	3 4	147 164



G0002194

Hardened & Ground Extension Sleeves				
System Code	Mounting Taper	Chuck Taper	Overall Length	Drawbar Thread
			mm	
G0002194 G0002194	R8 R8	B16 J6	135 132	7/16UNF 7/16UNF

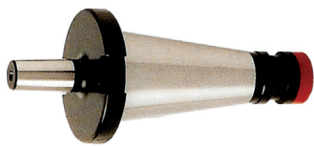

H0001440

Hardened & Ground ISO Drill Chuck Arbors				
System Code	Mounting Taper	Chuck Taper	Overall Length	Drawbar Thread
			mm	
H0001440 G0008292	ISO40 ISO50	B16 B16	143 182	M16 M24

Chucks



(DIN 228)

Hardened & Ground BT Drill Chuck Arbors			
System Code	Ext.	Int.	Length
			mm
2-1 3-1 3-2 4-1 4-2	2 3 3 4 4	1 1 2 1 2	92 99 112 124 124
4-3	4	3	140

Hardened & Ground BT Drill Chuck Arbors			
System Code	Ext.	Int.	Length
			mm
5-2 5-3 5-4 6-3 6-4	5 5 5 6 6	2 3 4 3 4	156 156 171 218 218
6-5	6	5	218

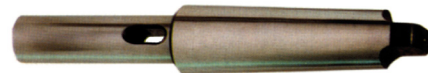

G0001290

Hardened & Ground Extension Sleeves				
System Code	Morse Taper Ext.	Morse Taper Int.	Overall Length	Parallel Length
			mm	mm
G0001290 G0001291 G0001292	2 2 2	1 2 3	160 175 196	76 91 112
G0001294 G0001296 G0001260 G0001261	3 3 3 3	1 2 3 4	175 194 215 240	78 91 112 137
G0001266 G0001267 G0001298	4 4 4	2 3 4	215 240 265	93 112 137
G0001268 G0001314 G0001315	5 5 5	3 4 5	268 300 335	116 137 172



A0034516

R8 Hardened & Ground Drill Sleeves				
System Code	Mounting Taper	Inside Taper	Overall Length	Drawbar Thread
			mm	
A0034516 G0001259 A0034519	R8 R8 R8	MT1 MT2 MT3	102 105 135	7/16UNF 7/16UNF 7/16UNF



A0024526

R8 Collets				
System Code	Mounting Taper	Inside Taper	Overall Length	Drawbar Thread
			mm	
A0034526	R8	6	101.6	7/16UNF
A0034517	R8	10	101.6	7/16UNF
A0034525	R8	12	101.6	7/16UNF
A0034518	R8	16	101.6	7/16UNF
G0008326	R8	20	101.6	7/16UNF



G0008333

R8 Shell Mill Arbors				
System Code	Mounting Taper	Spigot Ø	Overall Length	Drawbar Thread
			mm	
G0008333	R8	16	150	7/16UNF
G0008334	R8	22	159	7/16UNF
G0008335	R8	27	161	7/16UNF
G0008336	R8	32	170	7/16UNF



G0008282

Morse Taper Adaptors ISO Shanks				
System Code	Outside Taper	Inside Taper	Body Ø	Overall Length
			mm	mm
G0008282	ISO40	MT2	32	143
G0008283	ISO40	MT3	40	158
G0008284	ISO40	MT4	48	188
G0008298	ISO50	MT2	32	187
G0008299	ISO50	MT3	40	192
G0008300	ISO50	MT4	48	197



G0008276

ISO Face Mill Holders				
System Code	Shank	Spigot Ø	Driving Dog Width	Overall Length
			mm	mm
G0008276	ISO40	22	8	156
H0001443	ISO40	27	12	159
G0009482	ISO40	32	14	178
H0001446	ISO50	27	12	211
G0008294	ISO50	32	14	215
G0008295	ISO50	40	16	219



G0008488

BT Morse Taper Adaptors			
System Code	Shank	Length-Gauge Line to Front Nut	Morse Taper
G0008488	BT40	45	1
G0008489	BT40	50	2
G0008490	BT40	70	3
G0008491	BT40	95	4



BT40FMA16-45Q

BT40 Face Mill Arbors			
System Code	Shank	Length-Gauge Line to Front Nut	Spigot Ø mm
BT40FMA16-45Q	BT40	40	16
BT40FMA22-45Q	BT40	45	22
BT40FMA27-45Q	BT40	45	27
BT40FMA32-60Q	BT40	60	32
BT40FMA40-60Q	BT40	70	40



G0008314

Morse Taper Face Mill Holders				
System Code	Shank	Spigot Ø mm	Driving Dog Width mm	Drawbar Thread
G0008314	MT2	16	8	M10
G0008314	MT2	22	10	M10
G0008318	MT3	16	8	M12
G0008319	MT3	22	10	M12
G0008320	MT3	27	12	M12
G0008321	MT3	32	14	M12



G0008469

BT Combination Milling Arbors			
System Code	Shank	Length-Gauge Line to Front Nut	Spigot Ø
		mm	mm
G0008469	BT40	55	16
G0008470	BT40	55	22
G0008423	BT40	55	27
G0008471	BT40	60	32
BT40CMA40-60Y	BT40	60	40



G0008337

R8 Milling Arbors				
System Code	Shank	Spigot Ø	Working Length	Overall Length
		mm		
G0008337	R8	13	63	199
G0008338	R8	16	63	201
G0008339	R8	22	63	206
G0008340	R8	27	63	211
G0008342	R8	32	63	215



G0008497

BT Side Lock Holders			
System Code	Shank	Bore	Length-Gauge Line to Front
		mm	mm
G0008497	BT40	6	50
G0008498	BT40	8	63
G0008492	BT40	10	63
G0008493	BT40	12	63
G0008494	BT40	16	63
G0008428	BT40	20	63
G0008495	BT40	25	60
G0008429	BT40	32	100
G0008527	BT50	6	63
G0008528	BT50	8	65
G0008519	BT50	10	65
G0008520	BT50	12	80
G0008521	BT50	16	80
G0008522	BT50	20	80
G0008523	BT50	25	100
G0008524	BT50	32	105
G0008525	BT50	40	120
G0008526	BT50	50	120



H0001445

Supplied with spacers, but without running bushes.

ISO Long Milling Arbors				
System Code	Shank	Spigot Ø	Working Length	Spacer Ø
		mm		mm
H0001445	ISO40	22	315	34
G0008277	ISO40	22	400	34
G0008278	ISO40	27	315	41
G0008296	ISO50	27	500	41
ISO50LMA32X315	ISO50	32	315	47
G0008297	ISO50	32	500	47

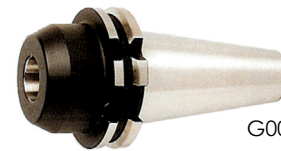

G0008675

Side Lock Holders (DIN 69871)			
System Code	Shank	Bore	Length-Gauge Line to Front mm
		mm	mm
G0008675	SK40	6	50
SK40SLH8-50Y	SK40	8	50
G0008670	SK40	10	50
G0008671	SK40	12	50
G0008672	SK40	16	63
G0008673	SK40	20	63
G0008674	SK40	25	100
SK40SLH32-100Y	SK40	32	100



ISO40SLH6C

ISO Side Lock Holders			
System Code	Shank	Bore	Length-Gauge Line to Front
		mm	mm
ISO40SLH6C	ISO40	6	50
ISO40SLH8C	ISO40	8	50
G0008285	ISO40	10	50
G0008286	ISO40	12	50
G0008287	ISO40	16	60
G0008288	ISO40	20	60
G0008289	ISO40	25	80
G0008290	ISO40	32	80
G0008305	ISO50	6	60
ISO50SLH8C	ISO50	8	60
G0008301	ISO50	10	65
ISO50SLH12C	ISO50	12	65
ISO50SLH16C	ISO50	16	65
G0008303	ISO50	20	65
G0008304	ISO50	25	80
H0001447	ISO50	32	80



G0008164

Milling Chucks for Threaded Shank End Mills			
System Code	Shank	End Mill Capacity	Collets
G0008164	2MT	20	6,10,12,16
G0008165	3MT	20	6,10,12,16
ACS ISO40Q	ISO40	20	6,10,12,16

Spare Collets			
System Code	Size (mm)	Stock Code	Size (mm)
G0008303	6	TC12Q	12
G0008347	10	TC16Q	16

MACHINE TOOLING



G0008313



BT40ER16-70Q

Morse Taper ER Milling Chucks

System Code	Collet	End Mill Clamping Range	Shank Ø	Draw Bar Thread
			mm	
G0008313	ER20	2-12	MT2	M10
G0008316	ER20	2-12	MT3	M12
G0008317	ER25	2-16	MT3	M12

BT ER Collet Chucks

System Code	Shank Ø	Collet	Clamping Range	Length-Gauge Line to front Nut	Front Nut Ø
			mm	mm	mm
BT40ER16-70Q	BT40	ER11	0.5-7	70	19
BT40ER20-70Q	BT40	ER20	1-13	70	34
BT40ER25-70Q	BT40	ER25	1-16	65	42
BT40ER32-70Q	BT40	ER32	2-20	75	50
BT40ER40-80Q	BT40	ER40	3-26	80	63
G0008509	BT50	ER25	1-16	100	42
G0008511	BT50	ER32	2-20	100	50
G0008515	BT50	ER40	3-26	100	63



SS16ER11-140Q

ER Collet Chucks (Straight Shank)

System Code	Collet	End Mill Clamping Range	Shank Ø	Overall Length	Shank Length
			mm		
SS16ER11-140Q	ER11	0.5-7	16	172	140
SS20ER16-140Q	ER16	2-10	20	182	140
SS20ER20-140Q	ER20	2-13	20	182	140



G0008474

ER Collet Chucks (Straight Shank)

System Code	Shank Ø	Collet	Clamping Range	Overall Length	Shank Length	Front Nut Ø
			mm			
G0008678	16	ER11	0.5-7	172	140	19
G0008679	20	ER16	0.5-10	172	140	28
G0008442	20	ER20	2-13	172	140	34
G0008680	25	ER16	0.5-10	190	140	34
G0008681	25	ER20	1-13	181	140	41

BT ER Collet Chucks

System Code	Shank Ø	Collet	Clamping Range	Length-Gauge Line to front Nut	Front Nut Ø
			mm	mm	mm
G0008474	BT40	ER11	0.5-7	70	19
G0008476	BT40	ER16	0.5-10	70	28
G0008477	BT40	ER20	1-13	70	34
G0008478	BT40	ER25	1-16	65	42
G0008424	BT40	ER32	2-20	75	50
G0008425	BT40	ER40	3-26	80	63



G0001286



G0008665

ER Collet Chucks (R8 Shank)

System Code	Shank Ø	Collet	Clamping Range	Length-Gauge Line to front Nut	Front Nut Ø
			mm	mm	mm
G0001286	R8	ER16	0.5-10	38	28
G0008331	R8	ER25	1-16	40	42
G0008332	R8	ER32	2-20	40	50
G0001287	R8	ER40	3-26	70	63

ER Collet Chucks (DIN 69871)

System Code	Shank Ø	Collet	Clamping Range	Length-Gauge Line to front Nut	Front Nut Ø
			mm	mm	mm
G0008665Y	SK40	ER11	0.5-7	70	19
G0008666	SK40	ER16	0.5-10	75	28
G0008667	SK40	ER20	1-13	75	34
SK40ER25-70Y	SK40	ER25	1-16	70	42
G0008668Y	SK40	ER32	2-20	75	50
G0008669	SK40	ER40	3-26	80	63



H0001442

ISO ER Collet Chucks

System Code	Shank Ø	Collet	Clamping Range	Length-Gauge Line to front Nut	Front Nut Ø
			mm	mm	mm
H0001442	ISO40	ER32	2-20	50	50
G0008275	ISO40	ER40	3-26	60	63



Case Hardened Steel - Ground to DIN 6499 Class 1 tolerances.
Collapsability: ER11-0.5 mm. ER16 to ER40-1.0 mm.

ER Collets						
Type	ER11	ER16	ER20	ER25	ER32	ER32
D	11.5	17	21	26	33	41
L	18	27	31	35	40	46

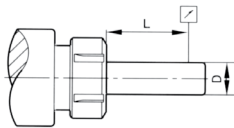

Collet Concentricity			
L	D	DIN 6499 Class 1	DIN 6499 Class 2
mm	mm		
6	1.0-1.4		
10	1.5-2.9	0.015	0.01
16	3.0-5.9		
25	6.0-9.9		
40	10.0-17.9		
50	18.0-26.9	0.02	0.015
60	27-34.9		



ER Collets - ER11			
System Code	Clamping Range	System Code	Clamping Range
	mm		mm
G0008172	1.0-0.5	ER114.5K	4.5-4.0
G0008171	1.5-1.0	ER115K	5.0-4.5
G0008174	2.0-1.5	ER115.5K	5.5-5.0
G0008173	2.5-2.0	ER116K	6.0-5.5
G0008176	3.0-2.5	ER116.5K	6.5-6.0
G0008175	3.5-3.0	ER117K	7.0-6.5
G0008178	4.0-3.5		

ER Collets - ER16			
System Code	Clamping Range	System Code	Clamping Range
	mm		mm
G0008188	1-0.5	ER166K	6-5
ER161.5K	1.5-1	ER167K	7-6
G0008189	2-1	ER168K	8-7
G0008190	3-2	ER169K	9-8
G0008191	4-3	ER1610K	10-9
A0032063	5-4		

ER Collets - ER20			
System Code	Clamping Range	System Code	Clamping Range
	mm		mm
G0008207	2-1.5	ER208K	8-7
G0008208	3-2.5	ER209K	9-8
G0008209	4-3	ER2010K	10-9
G0008210	5-4	ER2011K	11-10
G0008211	6-5	ER2012K	12-11
G0008212	7-6	ER2013K	13-12

ER Collets - ER25			
System Code	Clamping Range	System Code	Clamping Range
	mm		mm
G0008229	2-1.5	G0008222	10-9
G0008230	3-2	G0008223	11-10
G0008231	4-3	G0008224	12-11
G0008232	5-4	G0008225	13-12
G0008233	6-5	G0008226	14-13
G0008234	7-6	G0008227	15-14
G0008235	8-7	G0008228	16-15
G0008236	9-8		
G0008244	3-2.5	G0008135	12-11
G0008245	4-3	G0008240	13-12
G0008246	5-4	ER3214K	14-13
G0008140	6-5	G0008241	15-14
G0008247	7-6	D0000029	16-15
G0008248	8-7	G0008242	17-16
F0002474	9-8	D0000030	18-17
A0032074	10-9	G0008243	19-18
G0008239	11-10	G0008139	20-19

ER Collets - ER40			
System Code	Clamping Range	System Code	Clamping Range
	mm		mm
G0008264	4-3.5	G0008147	16-15
G0008265	5-4	G0008259	17-16
G0008253	6-5	G0008148	18-17
G0009429	7-6	G0008149	19-18
G0008155	8-7	G0008150	20-19
G0008266	9-8	G0008260	21-20
G0008143	10-9	G0008151	22-21
G0008144	11-10	G0008261	23-22
G0008145	12-11	G0008152	24-23
G0008257	13-12	G0008262	25-24
G0008146	14-13	G0008263	26-25
G0008258	15-14		



Castle Front Nuts				
System Code	To Suit Collet	Ø	Length	Thread MF
		mm	mm	
G0008344	ER11	16	8	13X0.75
G0008345	ER16	18	12	19X1.0
G0008346	ER20	19	19	24X1



Front Nuts with a Built-in Bearing Provide Substantially Higher Clamping Torque than Standard Clamping Nuts.

ER Front Nuts with Bearing			
System Code	To Suit Collet	Ø	Thread MF
		mm	
ER11BFN	ER11	19	M14 x 0.75
G0008195	ER16	28	M22 x 1.5
G0008213	ER20	34	M25 x 1.5
G0008237	ER25	42	M32 x 1.5
G0008249	ER32	50	M40 x 1.5
G0008267	ER40	63	M50 x 1.5



Spanners



G0008185 to G0008215



G0001276 to G0008156

ER Front Nut Spanners	
System Code	Nut
G0008185	ER11
G0008131	ER16
G0008215	ER20

ER Front Nut Spanners	
System Code	Nut
G0001276	ER25
F0002475	ER32
G0008156	ER40



ER25 to ER40

ER Front Nut Spanners	
System Code	Nut
ER25SQ	ER25
ER32SQ	ER32
ER40SQ	ER40



G0008186

Castle Nut Spanners	
System Code	To Suit Nut
G0008186	ER11
G0008197	ER16

Castle Nut Spanners	
System Code	To Suit Nut
G0008216	ER20

Hydraulic Milling Chucks

A manual type internal oil hole holder with a special seal, capable of long term operation without leakage. (Max. 1 800RPM).



BT40-OAS-20120

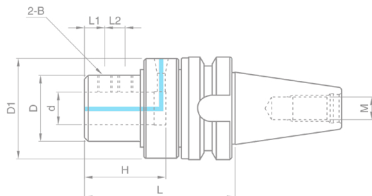

Oil Feed Holder

It has a bearing and a seal with outstanding heat-resistance and abrasion-resistant properties, making it capable of stable operation, for extended durations without leakage even in high speeds. (Max. 3 200RPM)



BT40-OAS-20120

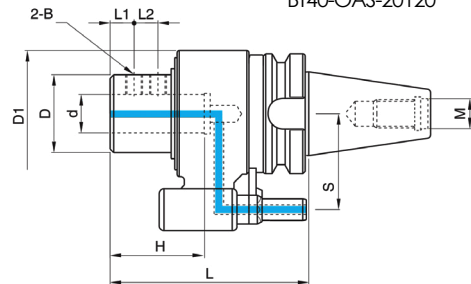

Hydraulic Milling Chucks

System Code	d	L	H	L1	L2	D	D1	S
BT40-OAS-20120	20	120	50	20	-	55	80	65
BT40-OAS-25140	25	140	60	20	20	55	80	65
BT40-OAS-32140	32	140	70	20	20	65	80	65
BT50-OAS-20145	20	145	50	20	-	55	100	80
BT50-OAS-25165	25	165	60	20	20	55	100	80
BT50-OAS-32165	32	165	70	20	20	65	100	80
BT50-OAS-40175	40	175	80	20	25	65	100	80

Available on Request

Drill Sleeves

DSL type Drill Sleeves are not compatible with the Weldon-B type Side lock Arbor.



H0001470

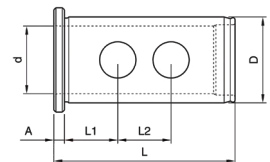

Hydraulic Milling Chucks

System Code	d	L	D	D1	H	L1	L2	M
BT40-OAS-20105	20	105	50	78	50	20	-	M16
BT40-OAS-25120	25	120	50	78	60	20	20	M16
BT40-OAS-32125	32	125	65	98	70	20	20	M16
BT50-OAS-20120	20	120	50	78	50	20	-	M24
BT50-OAS-25135	25	135	50	78	60	20	20	M24
BT50-OAS-32135	32	135	65	98	70	20	20	M24
BT50-OAS-40145	40	145	65	98	80	20	25	M24
BT50-OAS-50170	50	170	90	123	90	35	35	M24

Available on request

Hydraulic Drill Sleeves

System Code	D	d	L	L1	L2	A
H0001470	32	20	65	20	-	5
H0001471	32	25	65	20	20	5
H0001472	40	20	75	20	-	5
H0001473	40	25	75	20	25	5
H0001474	40	32	75	20	25	5
H0001475	50	20	95	35	-	5
H0001476	50	25	95	35	-	5
H0001477	50	32	95	35	35	5
H0001478	50	40	95	35	35	5

Drill Sleeves



MT4-SLA-32105

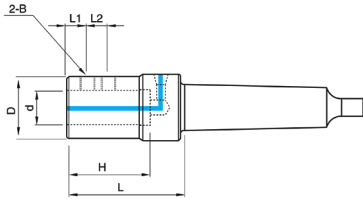

MT Side Lock Type						
System Code	D	L	D	H	L1	L2
MT4-SLA-32105	32	105	65	70	20	20
MT4-LA-40105	40	105	65	80	20	25
MT5-SLA-32105	32	105	65	70	20	20
MT5-SLA-40105	40	105	65	80	20	25
MT5-SLA-50130	50	130	90	90	35	35

MT Side Lock Oil Feed Type

A manual type internal oil hole holder with a special seal, capable of long term operation without leakage. (Max. 1 800RPM).



MT4-OMS-20080

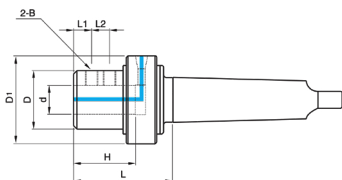

MT Side Lock Oil Feed Type Drill Sleeves							
System Code	D	L	D	D1	H	L1	L2
MT4-OMS-20080	20	80	50	78	50	20	-
MT4-OMS-25095	25	95	50	78	60	20	20
MT4-OMS-32100	32	100	65	98	70	20	20
MT5-OMS-20080	20	80	50	78	50	20	-
MT5-OMS-25095	25	95	50	78	60	20	20
MT5-OMS-32100	32	100	65	98	70	20	20
MT5-OMS-40110	40	110	75	98	80	20	25
MT5-OMS-50140	50	140	90	123	90	35	35
MT6-OMS-32105	32	105	65	98	70	20	20
MT6-OMS-40120	40	120	75	98	80	20	25
MT6-OMS-50140	50	140	90	123	90	35	35

Chucks

Used for tapping on machining centres with or without rigid-tap function.



G0008499

ER Tapping Chucks					
System Code	Shank	Tapping Range	Length from Gauge Line	Forward Float mm	Backward Float mm
		mm			
G0008599	BT40	M3-M12	70	8	4
BT40TER20	BT40	M4-M16	80	8	4
G0008500	BT40	M8-M27	100	10	4



G0008198

ER Tapping Collets					
System Code	Collet Size	Tap Size	Norm	Ø	Square
				mm	mm
G0008198	ER16	M3	DIN 371	3.5	2.7
G0008199	ER16	M4	DIN 371	4.5	3.4
G0008200	ER16	M5/M6	DIN 371	6.0	4.9
G0008201	ER16	M8	DIN 371	8.0	6.2
G0008219	ER20	M4	DIN 371	4.5	3.4
G0008220	ER20	M5/M6	DIN 371	6.0	4.9
G0008221	ER20	M8	DIN 371	8.0	6.2
G0008217	ER20	M10	DIN 371	10.0	8.0
G0008218	ER20	M12	DIN 376	9.0	7.0
G0008255	ER32	M5/M6	DIN 371	6.0	4.9
G0008256	ER32	M8	DIN 371	8.0	6.2
G0008251	ER32	M10	DIN 371	10.0	8.0
G0008252	ER32	M12	DIN 376	9.0	7.0
G0008253	ER32	M16	DIN 376	12.0	9.0
G0008254	ER32	M20	DIN 376	16.0	12.0



BT40TCM12

Quick Change Tapping Chucks					
System Code	Shank	Capacity	Body Outside Ø	Body Bore	Length from Gauge Line
BT40TCM12	BT40	M3-M12	36	19	64
BT40TCM20	BT40	M7-M20	53	31	97
BT40TCM36	BT40	M14-M36	78	48	149
BT50TCM12	BT50	M3-M12	36	19	64
BT50TCM20	BT50	M7-M20	53	31	97
BT50TCM36	BT50	M14-M36	78	48	149



Direct Drive (without clutch)



Tap Collets (M3-M12)				
System Code	Tap	Tap Shank	Tap Square	Collect Ø
G0008349	M3	3.15	2.5	19
G0008350	M3	3.5	2.7	19
G0008352	M4	4	3.15	19
G0008351	M4	4.5	3.4	19
G0008158	M5	5	4	19
G0008159	M5/M6	6	4.9	19
G0008353	M6	6.3	5	19
G0008354	M8	8	6.3	19
G0008348	M10	10	8	19
G0008355	M12	9	7.1	19

Tap Collets (M8-M20)				
System Code	Tap	Tap Shank	Tap Square	Collect Ø
TC208X6.3	M8	8	6.3	31
G0008358	M10	10	8	31
G0008364	M12	9	7.1	31
G0008360	M14	11	9	31
G0008359	M14	11.2	9	31
G0008160	M16	12	9	31
G0008361	M16	12.5	10	31
TC2014X11.2	M18/M20	14	11.2	31
G0008362	M20	16	12	31

Tap Collets (M14 - M36)				
System Code	Tap	Tap Shank	Tap Square	Collect Ø
G0008365	M14	11.2	9	48
G0008367	M16	12	9	48
G0008366	M16	12.5	10	48
TC3614X11.2	M18/M20	14	11.2	48
G0008368	M20	16	12	48
TC3616X12.5	M22	16	12.5	48
G0008161	M22/M24	18	14.5	48
G0008161	M24	18	14	48
G0008369	M27/M30	20	16	48
G0008370	M30	22	18	48
TC3622.4X18	M33	22.4	18	48
G0008371	M33/M36	25	20	48
TC3628X22	M36	28	22	48

Direct Drives (With Clutch - Adjustable Torque)



Tap Collets				
System Code	Tap	Tap Shank	Tap Square	Collect Ø
G0008374	M3	3.15	2.5	19
G0008375	M3	3.5	2.7	19
G0008377	M4	4	3.15	19
G0008376	M4	4.5	3.4	19
TCC125X4	M5	5	4	19

Tap Collets				
System Code	Tap	Tap Shank	Tap Square	Collect Ø
G0008380	M5/M6	6	4.9	19
G0008379	M6	6.3	5	19
G0008381	M8	8	6.3	19
G0008373	M10	10	8	19
G0008382	M12	9	7.1	19

Tap Collets (M8-M20)				
System Code	Tap	Tap Shank	Tap Square	Collect Ø
G0008390	M8	8	6.3	31
G0008383	M10	10	8	31
TCC209X7.1	M12	9	7.1	31
G0008385	M14	11	9	31
G0008384	M14	11.2	9	31
G0008387	M16	12	9	31
G0008386	M16	12.5	10	31
G0008388	M18/M20	14	11.2	31
G0008389	M20	16	12	31

Tap Collets (M14-M36)				
System Code	Tap	Tap Shank	Tap Square	Collect Ø
G0008392	M14	11.2	9	48
G0008394	M16	12	9	48
G0008393	M16	12.5	10	48
TCC3614X11.2	M18/M20	14	11.2	48
G0008396	M20	16	12	48
TCC3616X12.5	M22	16	12.5	48
G0008162	M22/M24	18	14.5	48
G0008162	M24	18	14	48
G0008397	M27/M30	20	16	48
G0008398	M30	22	18	48
TCC3622.4X18	M33	22.4	18	48
TCC3625X20	M33/M36	25	20	48
G0008399	M36	28	22	48

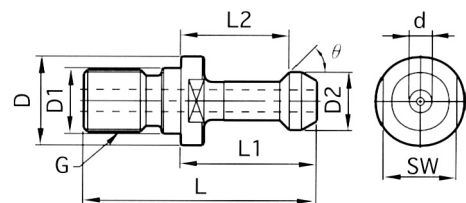
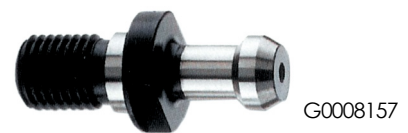

Pull Studs								
System Code	L	L1	L2	D	D1	D2	Ø	G
G0008157	60	35	28	23	17	15	45	M16
P40M2C	60	35	28	23	17	15	60	M16
G0008661	85	45	35	38	25	23	45	M24
P50M2C	85	45	35	38	25	23	60	M24

Pull Studs with a Through Coolant Hole								
System Code	L	L1	L2	D	D1	D2	Ø	G
G0009476	60	35	28	23	17	15	45	M16
P40M2CC	60	35	28	23	17	15	60	M16
P50M1CC	85	45	35	38	25	23	45	M24
P50M2CC	85	45	35	38	25	23	60	M24



G0003075

Hardness of Clamp Part HRC 55-60

5C Collets (Round)		
System Code	mm	Length
G0003075	6	83.3
G0003076	8	83.3
G0003070	10	83.3
G0003071	12	83.3
G0003072	16	83.3
G0003073	20	83.3
G0003074	25	83.3



G0008169

5C Collets (Round)			
System Code	Accepts Taper	Height	Base Length
		mm	mm
G0008169	BT/DIN/ISO40	171	130
G0008170	BT/DIN/ISO50	216	175



G0001386

Drill Drifts					
System Code	Size	Morse Taper	O/A Length	Height	Width
			mm	mm	mm
G0001386	1	1+2	140	20	5
A0031327	3	3	190	25	7
A0031328	4	4	225	30	10
A0031329	5	5+6	265	35	15



G0001548

DIN 318

Single Hand Drill Drifts		
System Code	To Eject Morse Tapers	Overall Length
		mm
G0001548	MT1, MT2, MT3	317
G0001549	MT4, MT5, MT6	380



G0007955

Hardened & Ground.

Dead Centres - Steel				Dead Centres - Steel			
System Code	Taper	Large	Length	System Code	Taper	Large	Length
		Ø	mm			Ø	mm
G0007955	MT1	12	80	G0007958	MT4	32	100
G0007956	MT2	17.8	100	G0007959	MT5	45	200
G0007958	MT3	24	125	DC6C	MT6	64	270



G0007990

Hardened & Ground.

Dead Centres - Carbide Tipped				Dead Centres - Carbide Tipped			
System Code	Taper	Large	Length	System Code	Taper	Large	Length
		Ø	mm			Ø	mm
G0007990	MT1	12	80	G0007993	MT4	32	100
G0007991	MT2	17.8	100	G0007994	MT5	45	200
G0007992	MT3	24	125	TCIDC6C	MT6	64	270



G0007949

Hardened & Ground Steel Tool. Sealed Ball Bearings.

Precision Revolving Centres							
System Code	Taper	Head Ø	Point Length	Max. Point Ø	Max. Load	Max. RPM	Run Out
		mm	mm	mm	Kg		mm
G0007949	MT2	45	24	20	200	7000	0.005
G0007947	MT3	60	31	25	500	5000	0.005
G0007948	MT4	70	41	32	800	3800	0.005
G0007965	MT5	90	50.5	40	2000	3000	0.005

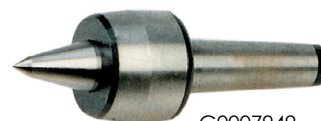

G0007949

Precision Revolving Centres							
System Code	Taper	Head Ø	Point Length	Max. Point Ø	Max. Load	Max. RPM	Run Out
		mm	mm	mm	Kg		mm
G0007949	MT2	45	34	20	140	7000	0.005
G0007950	MT3	60	47	25	400	5000	0.005
G0007951	MT4	70	53	32	500	3800	0.005
G0007952	MT5	90	65	40	1200	3000	0.005

Pictures may vary from the actual product.



G0007961



G0008037

Mono Block Jaws

Heavy-Duty Revolving Centres							
System Code	Taper	Body Ø	Max. Point	Point Length	Max. Radial Load	Max. RPM	Run Out
		mm	mm	mm	N		mm
G0007961	MT2	46	21	26	400	6000	0.005
G0007944	MT3	54	26	32	600	5000	0.005
G0007945	MT4	64	32	38	1000	4500	0.005
G0007946	MT5	84	42	46	2500	3500	0.005
G0007962	MT6	120	63	66	5000	1500	0.008

Three Jaw Self Centering Lathe Chucks with a Back Plate Mounting Prime Grip

System Code	Outside Ø	Max. Clamping Ø	Bore Ø	Max. RPM	Back Recess Ø
	mm	mm	mm		mm
G0008037	80	63	16	4000	55
G0008006	100	80	22	3500	72
G0008009	125	110	30	3000	95
G0001262	160	145	40	2500	130
G0008019	200	200	65	2000	165
G0001264	250	250	80	1600	206
G0008026	315	315	100	1200	272
3JSC380Q	380	380	135	1000	325



G0007967

Pipe Centres				
System Code	Taper	Large Ø	Small Ø	Angle of Head
		mm	mm	Degrees
G0007967	2MT	60	20	60
G0007968	2MT	60	12	75
G0007969	2MT	80	25	60
G0007973	2MT	80	12	75
G0007974	3MT	70	20	60
G0007975	3MT	70	12	75
G0007953	3MT	100	30	60
G0007971	3MT	100	32	75
G0007972	3MT	120	40	60
G0007973	3MT	120	32	75
G0007983	4MT	80	25	60
G0007984	4MT	80	12	75
G0007977	4MT	140	30	60
G0007978	4MT	100	32	75
G0007979	4MT	130	40	60
G0007980	4MT	130	35	75
G0007981	4MT	160	40	60
G0007982	4MT	160	35	75
G0007985	5MT	100	30	60
G0007986	5MT	100	32	75
G0007987	5MT	160	40	60
G0007988	5MT	160	35	75
G0007989	5MT	200	66	60
G0007954	5MT	200	40	75

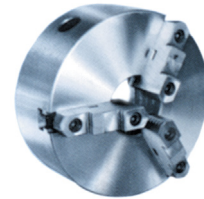

G0008011

Hard base jaws with reversible top jaws according to ISO 3442 standards

Three Jaw Self-Centering Lathe Chucks with a Back Plate Mounting Prime Grip

System Code	Outside Ø	Max. Clamping Ø	Bore Ø	Max. RPM	Back Recess Ø
	mm	mm	mm		mm
G0008011	160	160	40	2500	142
G0001263	200	200	65	2000	180
G0008023	250	250	80	1600	226
G0008025	315	315	100	1200	285
G0008030	325	325	100	1200	270
G0008032	380	380	125	1000	325
G0008033	400	400	130	1000	368
G0008034	500	500	210	800	465



G0007960

Interchangeable driving discs and centre points. Hydraulically equalised driving pins. Spring loaded centre point.

Face Driving Centres (Type FDC)					
System Code	Ø Turning Range	Clamping Range	Max. Point	Body Ø	Shank
	mm	mm	mm	mm	
G0007960	10-100	10-50	70	3MT	8

MACHINE TOOLING

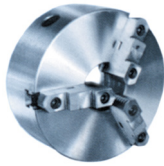

G0008010

Hard base jaws with reversible top jaws according to ISO 3442 standards

Three Jaw Self-Centering Lathe Chucks with a Back Plate Mounting Prime Grip

System Code	Out-side Ø	Spindle Ø	Bore Ø	Max. RPM	Stud P.C.D.
	mm				
G0008010	160	4	40	2500	82.6
G0008014	200	4	50	2000	82.6
G0008016	200	5	50	2000	104.8
G0008017	200	6	50	2000	133.4
G0008020	250	6	70	1600	133.4
G0008021	250	8	80	1600	171.4
G0008027	325	6	100	1200	133.4
G0008028	325	8	100	1200	171.4
G0008031	380	11	135	1000	235

DIN Mounting (Form C)

System Code	Out-side Ø	Spindle Ø	Bore Ø	Max. RPM	Stud P.C.D.
	mm				
G0008022	250	6	70	1600	133.4
G0008029	325	8	100	1200	171.4



G0008068

Four Jaw Self-Centering Lathe Chucks with a Back Plate Mounting

System Code	Out-side Ø	Max. Clamping Ø	Bore Ø	Max. RPM	Back Recess Ø
	mm				
G0008068	160	160	40	2500	130
G0008069	200	200	65	2000	165
G0008070	250	250	80	1600	206
G0008071	325	325	100	1200	272



G0008038

Four Jaw Independent Lathe Chucks with a Back Plate Mounting Prime Grip

System Code	Outside Ø	Max. Clamping Ø	Bore Ø	Back Recess Ø
	mm			
G0008038	100	100	25	72
G0008039	125	125	32	72
G0008040	160	160	45	65
G0008041	200	200	55	80
G0008043	250	250	75	110

Four Jaw Independent Lathe Chucks. Back Plate Mounting Prime Grip

System Code	Outside Ø	Max. Clamping Ø	Bore Ø	Back Recess Ø
	mm			
G0008000	320	320	95	140
G0008048	400	400	125	160
G0008051	500	500	160	200
G0008054	630	630	180	220
G0008056	800	800	210	250



G0008042

Four Jaw Independent Lathe Chucks. Direct Mounting Prime Grip - Camlock Mounting

System Code	Outside Ø	Spindle Ø	Bore Ø	Stud P.C.D.
	mm			
G0008042	200	4	56	82.6
G0008044	250	4	61	82.6
G0008045	250	5	75	104.8
G0007999	315	5	79	104.8
G0008000	320	6	79	133.4
G0008049	400	6	95	133.4
G0008050	400	8	125	171.4
G0008053	500	8	136	171.4
G0008052	500	11	160	235.0
G0008055	630	11	180	235.0



G0008001

Adaptor Plates DIN 55022

System Code	Chuck Ø	Spindle Ø
	mm	
G0008001	160	4
G0001339	160	5
G0001344	200	4
G0001345	200	5
G0001346	200	6

Adaptor Plates (DIN 55022)

System Code	Chuck Ø	Spindle Ø
	mm	
G0008003	250	6
G0001351	250	8
G0001355	315	6
AP315DIN8	315	8
G0001365	400	8



G0001336

Finished. For self centering lathe chucks.

Adaptor Plates - Camlock D1

System Code	Chuck Ø	Spindle Ø
	mm	
G0001336	160	3
G0001337	160	4
G0001338	160	5
G0001340	200	4
G0001341	200	5

Adaptor Plates - Camlock D1

System Code	Chuck Ø	Spindle Ø
	mm	
G0001354	315	8
G0001353	315	11
G0001357	325	6
G0001358	325	8
G0001356	325	11



Adaptor Plates - Camlock D1		
System Code	Chuck Ø	Spindle Ø
	mm	Inch
G0001342	200	6
G0001343	200	8
G0001348	250	4
G0008002	250	5
G0001349	250	6
G0001350	250	8
GP315CL6	315	6

Adaptor Plates - Camlock D1		
System Code	Chuck Ø	Spindle Ø
	mm	Inch
G0001361	380	6
G0001362	380	8
G0001360	380	11
G0001364	400	8
G0001363	400	11
G0001366	500	11



Black plate mounting and monoblock jaws

Three Jaw Self-Centering Lathe Scroll Chucks					
System Code	Outside Ø	Max. Clamping Ø	Bore Ø	Back Recess Ø	Max. RPM
	mm	mm	mm	mm	
G0008089	100	90	24	80	2500
G0008090	125	110	32	100	2500
G0008091	160	160	45	130	2000
G001254	200	220	58	160	2000
G0008093	250	260	89	220	1800
G0008096	315	300	105	260	1800

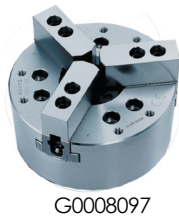

Direct Mounting and Split Jaws

Three Jaw Self-Centering Hollow Bore Power Chucks						
System Code	Outside Ø	Spindle Nose	Bore Ø	Jaw Stroke	Max. RPM	Max. Gripping Force
	mm	mm	mm	mm		Kg / F
G0008097	169	A5	45	5.5	6000	5710
G0008098	210	A6	52	7.4	4800	8360
G0008101	254	A8	75	8.8	4200	11010



Cast Iron

Bench Vices with Swivel Bases				
System Code	Jaw Width	Max. Opening	Jaw Height	Weight
	mm	mm	mm	Kg
A0018667	90	100	50	7
A0018675	130	150	70	14
A0018677	180	200	80	20

Bench Vices with Swivel Bases (Heavy Duty)				
System Code	Jaw Width	Max. Opening	Jaw Height	Weight
	mm	mm	mm	Kg
A0018676	150	180	108	26

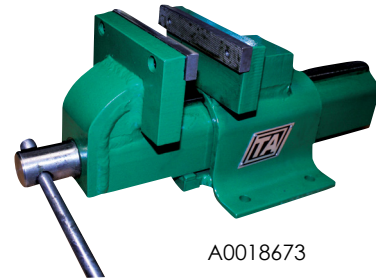

Fabricated All-Steel Bench Vice				
System Code	Jaw Width	Max. Opening	Jaw Height	Weight
	mm	mm	mm	Kg
A0018673	150	190	78	22



Complete with a swivel base

Swivel Base Bench Vices			
System Code	Jaw Width	Jaw Opening	Weight
	mm	mm	Kg
A0018712	80	70	6
A0018709	100	105	12.5
A0018710	125	115	20
A0018711	150	125	30



Standard Drill Vices				
System Code	Jaw Width	Max. Opening	Jaw Height	Weight
	mm	mm	mm	Kg
A0018680	75	50	20	2.0
A0018668	100	75	23	3.1
A0018669	125	100	26	3.1
A0018670	150	125	30	3.3
A0018671	200	175	35	4.6

MACHINE TOOLING



A0018688

Jaws, slides and guides hardened and ground.

Premium Quality Drill Vices				
System Code	Jaw Width	Max. Opening	Jaw Height	Clamp Slot Width
	mm	mm	mm	mm
A0018688	80	61	25	11
A0018686	100	87	30	13.5
A0018687	125	108	30	13.5



A0018698

Tilting Drill Vices				
System Code	Jaw Width	Max. Opening	Jaw Height	Weight
	mm	mm	mm	mm
A0018698	85	80	32	5.2
A0018697	115	90	40	8

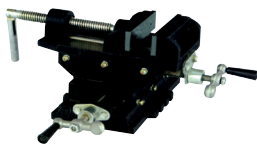

A0018678

Compound Drill Vices					
System Code	Jaw Width	Max. Opening	Jaw Height	Stroke Length	Cross Stroke
	mm	mm	mm	mm	mm
A0018678	152	135	42	100	100

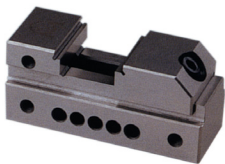

A0018700

Used for high accuracy light machining, inspection or marking out of precision components. A vice can be used standing on its base, side, end or top. Guaranteed within 0.005 mm in parallelism, flatness and squareness, with the vice in any mode. Manufactured from high grade, oil hardening cast steel hardened and tempered to ensure stability and accuracy throughout the unit's working life.

Toolmaker Vices				
System Code	Jaw Width	Length	Jaw Opening	Jaw Depth
	mm	mm	mm	mm
A0018700	50	140	65	25
A0018701	63	175	85	32
A0018702	73	190	100	35
A0018699	100	245	125	45

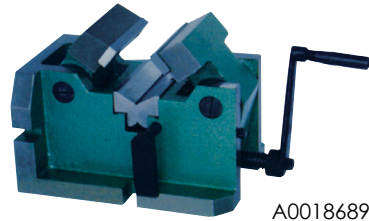

A0018689



Pipe Vices		
System Code	Jaw Width	Clamping Range Ø
	mm	mm
A0018689	100	10-80

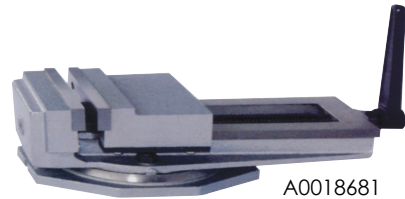

A0018681

With an unguarded lead screw

Machine Vices				
System Code	Jaw Width	Length	Jaw Opening	Jaw Height
	mm	mm	mm	mm
A0018681	160	350	130	50
A0018672	200	440	220	63

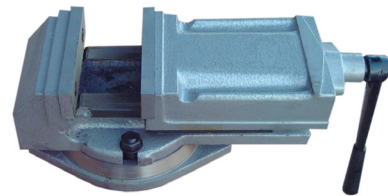

A0018682

Swivel Base Milling Machine Vices				
System Code	Jaw Width	Jaw Height	Max. Opening	Overall Length
	mm	mm	mm	mm
A0018682	100	35	80	240
A0018683	125	40	100	290
G0001334	160	52	125	390
A0018685	200	63	160	430

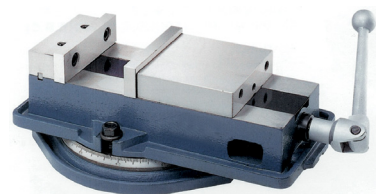

G0002247

Accu-Lock Down Grip Vice Machine					
System Code	Jaw Width	Jaw Height	Max. Opening	Overall Length	Parallelism Top Surface to Bottom Over 100
	mm	mm	mm	mm	mm
G0002247	100	32	100	337	0.015
G0002248	125	40	110	377	0.015
G0001334	160	45	140	448	0.015
G0002252	200	56	190	540	0.015

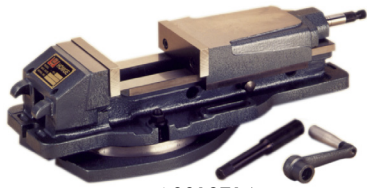

A0018714

Adjustable clamping force with a high tensile cast iron body. Hardened and ground slide ways.



G0002241

Tilting Angle Plates				
System Code	Length	Width	Height	T. Slot Width
	mm	mm	mm	mm
G0002241	180	130	91	10
G0002242	250	175	133	12
G0002243	380	260	185	16
G0002244	600	310	205	16

Hydraulic Machine Vices					
System Code	Jaw Width	Jaw Opening	Jaw Height	Vice Length	Clamping Force
	mm	mm	mm	mm	Kg
A0018714	100	170	36	430	2500
A0018715	125	220	46	540	3500
A0018706	150	300	51	620	4500
G0003689	200	300	62	700	8500



A0018703



G0001280

Tilting & Swiveling Machine Vices				
System Code	Jaw Width	Jaw Length	Opening	Jaw Height
	mm	mm	mm	mm
A0018703	100	505	170	36
A0018704	150	490	310	58

Sets of Plates				
System Code	No. of Pairs per Set	Width	Length	Height Range
		mm	mm	mm
G0001280	9	6.35	150	19-41
G0001281	13	5	150	14-50
G0001282	13	10	150	14-50



G0001269



A0018618

Sold in Pairs.

Angle Plates - Slotted			
System Code	Width	Height	Depth
	mm	mm	mm
G0001269	75	63	50
G0001367	90	75	63
G0001335	112	88	75
A0018602	150	125	112
A0018603	200	150	125
G0001347	250	200	150
G0001352	300	225	200

Machinists V-Blocks				
System Code	Length	Width	Height	Width Across V
	mm	mm	mm	mm
A0018618	75	32	60	45
A0018612	100	40	65	50
A0018613	125	50	80	50
A0018614	150	63	87	80
A0018615	200	100	112	100
A0018616	250	125	165	125
A0018617	300	175	200	162



A0018645

Universal V-Blocks				
System Code	Capacity Ø	V-Block Length	V-Block Width	V-Block Height
	mm	mm	mm	mm
A0018645	32	35	20	32

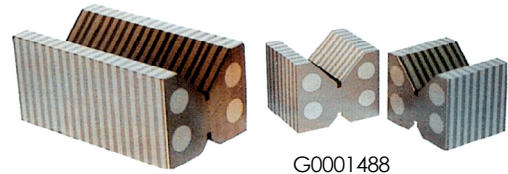

G0001488

Magnetic Transfer V-Blocks				
System Code	Length	Width	Height	Unit
	mm	mm	mm	
G0001488	50	60	48	Pair
G0001489	110	60	48	Each

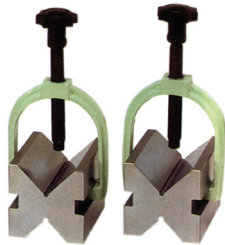

A0018647

V-Block and Clamp Sets				
System Code	Length	Width	Height	Clamping Capacity
	mm	mm	mm	mm
A0018647	50	40	50	30
A0018644	75	55	55	50
A0018646	100	75	70	70

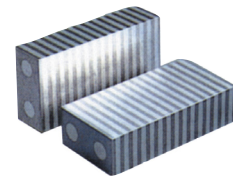

Sold in pairs

Magnetic Transfer Blocks			
System Code	Length	Width	Height
	mm	mm	mm
G0001450	100	50	25



A0018052

Pot Magnets					
System Code	Diameter	Height	Tapped Hole	Magnetic	Pull
		mm		Kg	
A0018052	17	16	M6	2.6	25
A0018053	22	19	M6	4.2	41
A0018054	27	25.4	M6	7	68
A0018055	35	30	M6	20	190
A0018056	65	43	M12	41	400



A0028865

Magnetic V-Blocks - Long				
System Code	Length	Height	Width	Magnetic Force
	mm	mm	mm	mm
A0028865	100	95	70	588

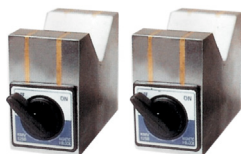

A0018642

Magnetic V-Blocks - Short				
System Code	Length	Height	Width	Magnetic Force
	mm	mm	mm	mm
A0018642	50	80	100	196



B0001382

Magnetic Lifters					
System Code	Height	Width	Length	Magnetic	Pull
	mm	mm	mm	N	Kg
B0001382	55	50	63	588	60
B0001384	55	50	69	748	80
B0001385	55	50	88	900	100
B0001379	55	50	118	1178	120



A0001829

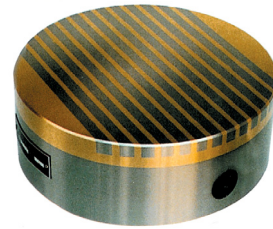

G0001381

Permanent Magnetic Chucks (Circular)			
System Code	Ø	Height	Magnetic Pull
	mm	mm	N / cm ²
G0001381	160	66	≥80
G0001275	200	73	≥80
G0001382	250	80	≥80
G0001383	300	94	≥120

Permanent Magnetic Lifters				
System Code	Steel Plate	Round Steel	Max. Pull of Force	Weight
	mm	mm	Kg	Kg
A0001829	100	50	350	3
B0001381	300	150	1050	12
B0001383	600	300	2100	25
B0001378	1000	500	3500	43
B0001380	2000	1000	6000	85



A0023267

Demagnetisers				
System Code	Capacity	Length	Width	Height
	mm	mm	mm	mm
A0023267	100VA	160	125	85
A0023269	300VA	200	160	120



G0001278



G0002377

Permanent Magnetic Chucks (High Power Rectangular)				
System Code	Width	Length	Height	Magnetic Pull
	mm	mm	mm	N / cm ²
G0001278	120	254	48	≤120
B0001387	150	300	48	≤120
B0001388	150	350	48	≤120
B0001390	200	400	48	≤120
B0001391	200	500	48	≤120
B0001392	200	600	48	≤120
B0001393	250	500	53	≤120
B0001394	250	600	53	≤120

For vertical/horizontal operation. Supplied with a master indexing plate with 24 index positions and additional plates having 2, 3, 4, 6, 8 and 12 index positions.

NOTE: Supplied without three jaw chuck. Tail stock available on request. Height dimensions may change.

Simple Indexer					
System Code	To Suit Chuck Ø	Face Plate	Centre Height	Overall Height	Width
	mm	mm	mm	mm	mm
G0002377	150	167	130	218	156
G0002379	200	210	149.25	257	173

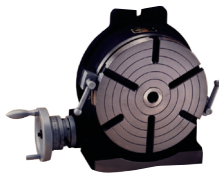

G0002329

The worm drive is hardened and ground. Graduated through 360°. One turn of the handle moves the table 4°.

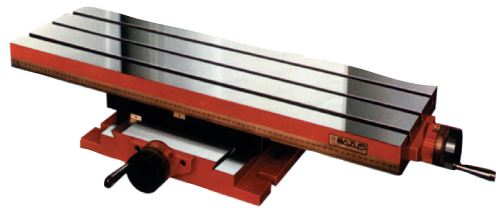

G0002704

Horizontal/Vertical Rotary Tables					
System Code	Table Ø	Height	Base	Centre Sleeve MT	Worm Gear Ratio
	mm	mm	mm		
G0002329	150	78	220x160	2	90:1
G0002331	200	110	310x225	3	90:1
G0002332	250	110	320x280	3	90:1
G0002333	300	140	410x325	4	90:1
G0002334	350	140	460x380	4	90:1
G0003713	400	150	510x435	5	90:1

Compound Tables (Type CT)							
System Code	Table Length	Table Width	Base Length	Base Width	X Travel	Y Axis Travel	T Slot Width
	mm	mm	mm	mm	mm	mm	mm
G0002704	240	190	195	155	120	140	12
G0002705	340	190	195	155	200	140	12
G0002707	430	240	260	190	280	180	12
G0002708	600	240	260	190	400	180	12

NOTE: Without indexing plates or lathe chuck

Semi-Universal Dividing Head

Dividing Ratio: 1:40. Base and head block - stabilized cast iron. Head stock spindle is made from chrome nickel steel, hardened (hrc 60) and ground. Standard accessories: indexing plates and tail stock.

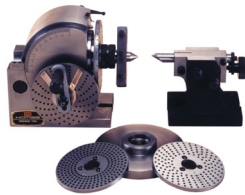

G0002221



G0002376

Horizontal /Vertical Rotary Tables				
System Code	Centre Height	Lathe Chuck Ø	Height	Width
	mm	mm	mm	mm
G0002221	100	100/125	173	140
G0002222	128	125/150	220	156

Right Angle Heads			
System Code	Driving Spindle	Output Spindle	Arbor Ø
		mm	mm
G0002376	R8	R8	22
G0002336	ISO40	R8	22

NOTE: Supplied without lathe chuck.



G0002223

Sold with gear train for spiral milling. Dividing Ratio: 1:40. Base and Head Block is made from stabilized Cast Iron. Head Stock Spindle is made from Chrome Nickel Steel, Hardened (HRC 60) and Ground. Standard accessories: Gear train, tailstock and indexing plates.



G0001499

Universal Heads				
System Code	Centre Height	Lathe Chuck Ø	Height	Width
	mm	mm	mm	mm
G0002223	132.7	150/180	236	272

Power Feed Attachments			
System Code	Axis	Speed	Torque
		RPM	Nm
G0001499	X	0-200	16
G0001499	X	0-200	16
G0002361	Y	0-200	16
G0002362	Z	0-200	16

NOTE: Supplied Without Lathe Chuck.



Forty Position Quick Change Tool Posts

The tool post has a body with a ground tooth coupling. Toolholders are clamped against the ground teeth with a dual clamping system with an eccentric cam. Forty clamping positions are possible. The system ensures superior rigidity and precision. Precision repeatability is within 0.01 mm.

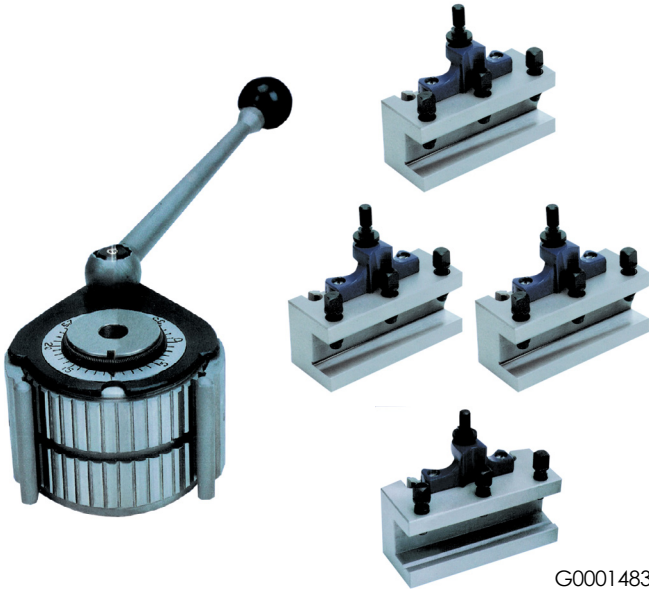

G0001483

The set comprises of 1 turret, 3 turning toolholders and 1 toolholder with a V-groove for use with boring bars.

Sets				
System Code	Series	Lathe Swing	Max. Toolholder SQ	Max. Toolholder Length
		mm	mm	mm
G0001483	A0	120-220	12	12
G0001484	A1	150-300	20	20
G0001487	E5	200-400	20	30
G0001485	B2	300-500	25	32
G0001486	C3	400-700	32	40

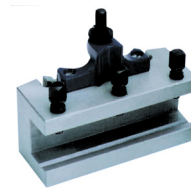

G0001456

Boring Bar Holders			
System Code	Series	Boring Bar	Boring Bar Length
	mm	mm	mm
G0001456	A0	12	50
G0001457	A1	20	90
G0001461	E5	30	100
G0001458	B2	32	130
G0001459	C3	40	160

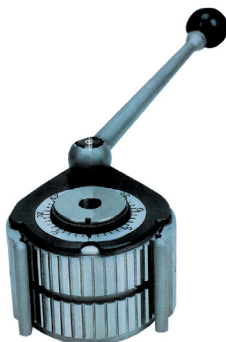

G0001468

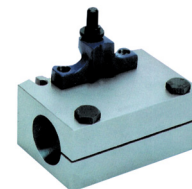

G0001462

Turrets					
System Code	Series	Lathe Swing	Max. Tool Holder SQ	Max. tool-holder Length	Max. Boring Bar Ø
		mm	mm	mm	mm
G0001468	A0	120-220	12	50	12
G0001469	A1	150-300	20	90	20
G0001473	E5	200-400	25	100	30
G0001470	B2	300-500	32	140	32
G0001471	C3	400-700	40	170	40
G0001472	D1	600-1000	63	180	50

Drill Holders					
System Code	Series	Holder Bore	Holder Length	Max. Morse Taper	Max. Drill Ø
	mm	mm	mm		
G0001462	A0	15	50	1MT	14
G0001463	A1	30	80	2MT	23
G0001467	E5	40	100	3MT	31.5
G0001464	B2	40	140	4MT	50
G0001465	C3	40	150	4MT	50

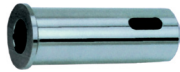

MQCBA0

Morse Taper Bushes					
System Code	Series	Outside	Length	Max. Morse Taper	Max. Drill Ø
		mm	mm	mm	
MQCBA0	A0	15	50	1MT	14
G0001451	A1	30	80	2MT	23
G0001455	E5	40	100	3MT	31,5
G0001452	B2	40	140	4MT	50
G0001453	C3	40	150	4MT	50
G0001454	D1	63	185	5MT	76

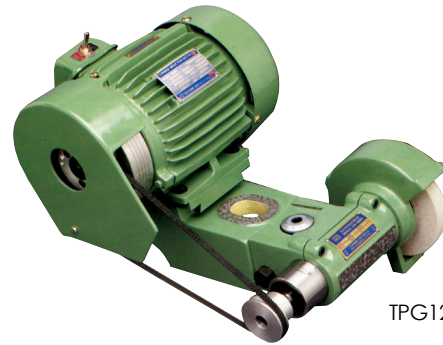

TPG125S

Tool post Grinders					
System Code	Wheel Ø	Motor Power	Distance from Centre to Base	Height	Over-all Length
	mm	HP	mm	mm	mm
TPG125S	125	1/2	38	240	440
TPG180S	180	1	40	270	485
TPG250S	250	2	55	360	455

TPG250-IS - External only
An internal arbor is an optional extra

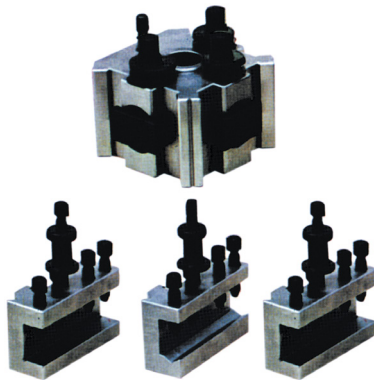

G0001535

Supplied with 4 toolholders: 3 standard for external Tools and 1 with a V for Boring Bars.

Quick Change Tool Posts							
System Code	Size	Centre Height	Height from Centre to Toolpost		Turning Tool	Boring Bar Ø	Morse Taper
		mm	Min. mm	Max. mm			
G0001535	M	120	24	34	16x16	14	1
G0001533	AP	140	25	41	16x16	16	1
G0001283	A	170	32	42	20x20	18	2
G0001284	BP	200	38	53	25x25	20	3
G0001284	B	230	47	65	32x32	24	3
G0001285	C	280	51	72	32x32	26	4
QCTPD	D	350	61	95	40x40	36	4
QCTPE	E	450	75	111	50x50	38	5



G0001532

Standard Tool Holders			
System Code	Series	Shank SQ	Shank Length
	mm	mm	mm
G0001532	M	16	50
G0001520	AP	16	60
G0001277	A	20	65
G0001282	BP	25	85
G0001282	B	32	100
G0001529	C	32	120

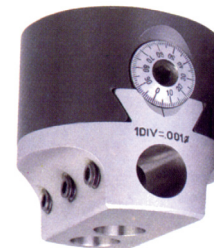

G0001274

Standard Boring Heads			
System Code	Head Ø	Head Length Ø	Boring Bar Ø
	mm	mm	mm
G0001274	50	62	12
G0001368	75	80	18
G0001273	100	90	25



G0008330

Arbors		
System Code	Taper	To Suit Head
G0008330	R8	50-75-100
G0001297	3MT	50-75-100
G0001305	4MT	50-75-100
G0008274	ISO30	50-75-100
H0001441	ISO40	50-75-100



G0002397

Supplied without an arbor. Vernier scale: 1 Division = 0.01 mm on Ø.

Auto Boring and Facing Heads						
System Code	Max. Facing Ø	Max. Boring Ø	Slide Travel	Manual Return	Head Ø	Boring Bar Ø
	mm	mm	mm	mm/rev	mm	mm
G0002397	220	160	36	3	78	16
G0002398	330	230	56	3	115	25
G0002399	380	280	80	3	140	25
G0002395	430	340	110	3	140	25
BFH125B	600	380	125	4	190	32
G0002396	680	450	160	4	190	32

Forged steel with brass shoes.



A0018717

Universal Ball Joint Clamps				
System Code	Length	Width	Stud	Table T Slot Width
	mm	mm		mm/rev
A0018717	125	37	M12	14
A0018718	150	47	M16	18



G0007995

Arbors		
System Code	Taper	Head
G0007795	R8	36
G0007996	R8	56
G0008404	ISO30	36
G0008406	ISO40	36
G0008405	ISO40	56/80/110
G0002389	ISO50	56/80/110/125/160

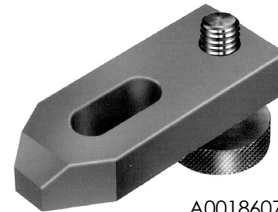

A0018607

Plain Adjustable Clamps					
System Code	T Bolt	Length	Width	Thickness	Slot Width
		mm	mm	mm	mm
A0018607	M10	80	30	15	11
A0018605	M12	100	40	20	15
A0018606	M12	125	50	25	18



G0002999

Reversing Tap Chucks					
System Code	Trapping Range	Mounting Taper	Forward Float	Backward Float	Front Nut Ø
	mm	mm	mm	mm/rev	mm
G0002999	M2-M7	B16	3.5	5	23
G0000419	M4-M12	B16	4.5	5	28
G0001331	M8-M20	M20	6	6	40

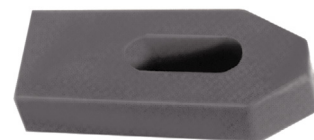

A0018636

DIN 6314

Plain Clamps						
System Code	T Bolt	Length	Width	Height	Slot Width	Slot Length
		mm	mm	mm	mm	mm
A0018626	M6	50	20	10	7	20
A0018627	M8	60	25	12	9	22
A0018628	M10	80	30	15	11	30
A0018629	M12/14	100	40	20	14	40
A0018630	M12/14	125	40	20	14	50
A0018631	M16/18	125	50	25	18	45
A0018632	M16/18	160	50	25	18	65
A0018633	M20/22	160	60	30	22	60
A0018634	M20/22	200	60	30	22	80
A0018635	M24	200	70	30	26	80



207NB16

Non-Reversing Tap Chucks					
System Code	Trapping Range	Mounting Taper	Forward Float	Backward Float	Front Nut Ø
	mm	mm	mm	mm/rev	mm
207NB16	M2-M7	B16	5	5	23
412NJ6	M4-M12	BJ6	5	5	28
820N	M8-M20	M20	8	6	40

MACHINE TOOLING

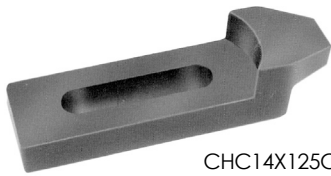

CHC14X125C

Cranked Heel Clamps					
System Code	T Bolt	Length	Width	Height	Slot Width
		mm	mm	mm	mm
CHC14X125C	M12	125	40	20	14
CHC14X160C	M14	160	50	25	16
A0018609	M16	160	50	25	18
A0018610	M20	160	60	30	22



DIN 6315B

A0018626

Open End Clamps					
System Code	T Bolt	Length	Width	Height	Slot Width
		mm	mm	mm	mm
A0018626	M6	60	19	12	7
A0018627	M8	80	25	15	9
A0018619	M10	100	31	20	11
A0018620	M12/14	125	38	25	14
A0018621	M16/18	160	48	30	18
A0018622	M16/18	200	52	30	18
A0018623	M20/22	200	62	40	22
A0018624	M24	200	66	40	26
A0018625	M24	315	66	40	26



A0018392

DIN 6314Z
To be used with step blocks (DIN 6500).

Stepped Clamps						
System Code	T Bolt	Length	Width	Height	Slot Width	Slot Length
		mm	mm	mm	mm	mm
A0018392	M6	50	20	10	7	20
A0018393	M8	60	25	12	9	22
A0018384	M10	80	30	15	11	30
A0018385	M12/14	100	40	20	14	40
A0018387	M16/18	125	50	25	18	45
A0018390	M20/22	160	60	30	22	60
A0018391	M24	200	70	30	26	80



DIN 6500

A0018586

Universal Step Blocks				
System Code	Size	Max. Rising Height	Step Block Height	Step Block Width
		mm	mm	mm
A0018586	1	51	33	19
A0018587	2	107	66	35.5
A0018583	3	208	131	68

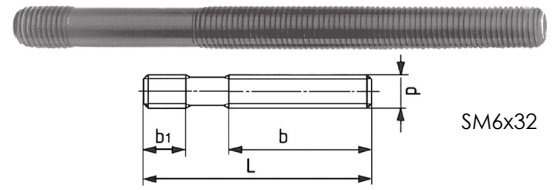

SM6x32

DIN 6379. Execution: Heat treated, rolled thread.
Tensile Strength Class: 8.8.

High Tensile Studs (Type S)				
System Code	d	L	b	b1
A0018451	M6	32	16	9
A0018452	M6	40	20	9
A0018453	M6	50	30	9
A0018454	M6	63	40	9
SM6x80	M6	80	50	9
A0018457	M8	40	20	11
A0018458	M8	63	40	11
A0018455	M8	100	63	11
A0018456	M8	160	100	11
A0018401	M10	50	25	13
A0018402	M10	80	50	13
SM10x100	M10	100	75	13
SM10x125	M10	125	75	13
SM10x160	M10	160	100	13
SM10x200	M10	200	125	13
SM12x50	M12	50	25	15
SM12x63	M12	63	32	15
SM12x80	M12	80	50	15
SM12x100	M12	100	63	15
SM12x125	M12	125	75	15
SM12x160	M12	160	100	15
SM12x200	M12	200	125	15
SM14x63	M14	63	32	17
SM14x100	M14	100	63	17
SM14x160	M14	160	100	17
SM14x200	M14	200	125	17
SM14x250	M14	250	160	17
SM16x63	M16	63	32	19
SM16x80	M16	80	50	19
SM16x100	M16	100	63	19
SM16x125	M16	125	75	19
SM16x160	M16	160	100	19
SM16x200	M16	200	125	19
SM16x250	M16	250	160	19
SM16x315	M16	315	180	19
SM16x500	M16	500	315	19
SM18x80	M18	80	50	23
SM18x125	M18	125	75	23
SM18x160	M18	160	100	23
SM18x200	M18	200	125	23
SM18x250	M18	250	150	23
SM18x315	M18	315	180	23
SM20x80	M20	80	32	27
SM20x125	M20	125	70	27
SM20x160	M20	160	100	27
SM20x200	M20	200	125	27
SM20x250	M20	250	160	27
SM20x315	M20	315	200	27
SM20x400	M20	400	250	27
SM20x500	M20	500	315	27
SM22x100	M22	100	45	31
SM22x160	M22	160	100	31
SM22x200	M22	200	125	31



High Tensile Bolts (Type TB)				
System Code	d	L	b	b1
SM22x250	M22	250	160	31
SM22x315	M22	315	180	31
SM22x400	M22	400	250	31
SM24x100	M24	100	45	35
SM24x125	M24	125	70	35
SM24x160	M24	160	100	35
SM24x200	M24	200	125	35
SM24x250	M24	250	160	35
SM24x315	M24	315	200	35
SM24x400	M24	400	250	35
SM24x500	M24	500	315	35
SM24x630	M24	630	315	35



A0018553

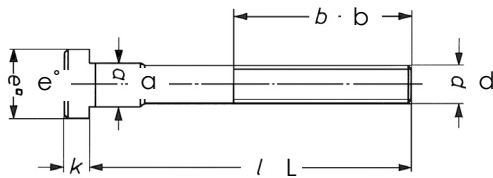

DIN 787. Execution: Forged, Heat Treated, Milled Head, Rolled Thread.
Tensile Strength Class: M6-M12 Class 10.9,
M14-M42 Class 8.8.

High Tensile T-Bolts (Type TB)					
System Code	d x i x L	b	a	e	k
A0018553	M 6x 6x 25	15	5.7	10	4
A0018554	M 6x 6x 40	28	5.7	10	4
TB6M6x63	M 6x 6x 63	40	5.7	10	4
A0018555	M 8x 8x 32	22	7.7	13	6
A0018556	M 8x 8x 50	35	7.7	13	6
A0018557	M 8x 8x 80	50	7.7	13	6
A0018490	M10x10x 40	30	9.7	15	6
A0018491	M10x10x 63	45	9.7	15	6
A0018489	M10x10x 100	60	9.7	15	6
A0018494	M12x12x 50	35	11.7	18	7
A0018495	M12x12x 63	40	11.7	18	7
A0018496	M12x12x 80	55	11.7	18	7
A0018492	M12x12x 125	75	11.7	18	7
A0018493	M12x12x 200	120	11.7	18	7
A0018498	M12x14x 50	35	13.7	22	8
A0018499	M12x14x 63	45	13.7	22	8
A0018500	M12x14x 80	55	13.7	22	8
A0018497	M12x14x 125	75	13.7	22	8
TB14M12x200	M12x14x 200	120	13.7	22	8
A0018505	M14x16x 63	45	15.7	25	9
A0018501	M14x16x 100	65	15.7	25	9
A0018503	M14x16x 160	100	15.7	25	9
A0018504	M14x16x 250	150	15.7	25	9
A0018510	M16x16x 63	45	15.7	25	9
A0018511	M16x16x 80	55	15.7	25	9
A0018506	M16x16x 100	65	15.7	25	9
A0018507	M16x16x 160	100	15.7	25	9
A0018508	M16x16x 200	125	15.7	25	9
A0018509	M16x16x 250	150	15.7	25	9
A0018516	M16x18x 63	45	17.7	28	10
A0018517	M16x18x 80	55	17.7	28	10
A0018512	M16x18x 100	65	17.7	28	10
A0018514	M16x18x 160	100	17.7	28	10

High Tensile T-Bolts (Type TB)					
System Code	d x i x L	b	a	e	k
A0018515	M16x18x200	125	17.7	28	10
TB18M16x250	M16x18x 250	150	17.7	28	10
A0018524	M20x80 80	55	19.7	32	12
A0018518	M20x20 100	65	19.7	32	12
A0018519	M20x20 125	85	19.7	32	12
A0018520	M20x20 160	110	19.7	32	12
A0018521	M20x20 200	125	19.7	32	12
A0018522	M20x20 250	150	19.7	32	12
A0018523	M20x20 315	190	19.7	32	12
TB22M20x80	M20x22 80	55	21.7	35	14
A0018525	M20x22 100	65	21.7	35	14
A0018526	M20x22 125	85	21.7	35	14
A0018527	M20x22 160	110	21.7	35	14
A0018528	M20x22x200	125	21.7	35	14
A0018529	M20x22x250	150	21.7	35	14
A0018530	M20x22x315	190	21.7	35	14
A0018531	M24x24x100	70	23.7	40	16
A0018532	M24x24x125	85	23.7	40	16
A0018533	M24x24x160	110	23.7	40	16
A0018534	M24x24x200	125	23.7	40	16
A0018535	M24x24x250	150	23.7	40	16
A0018536	M24x24x315	190	23.7	40	16
A0018537	M24x24x400	240	23.7	40	16
A0018538	M24x28x100	70	27.7	44	18
A0018539	M24x28x125	85	27.7	44	18
A0018541	M24x28x200	125	27.7	44	18
A0018538	M24x28x250	150	27.7	44	18
A0018539	M24x28x315	190	27.7	44	18
A0018541	M24x28x400	240	27.7	44	18

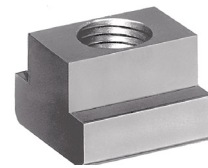

A0018582

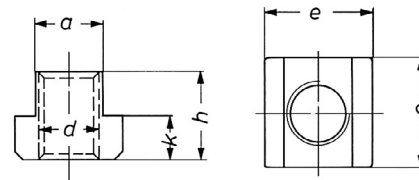

DIN 508. Tensile Strength - 1000 N/ mm².

High Tensile T-Nuts (Type TN)					
System Code	d x i x L	b	a	e	k
A0018582	M5x6	5.7	10	8	4
A0018583	M6x8	7.7	13	10	6
A0018301	M8x10	9.7	15	12	6
A0018302	M10x12	11.7	18	14	7
A0018303	M12x14	13.7	22	16	8
A0018094	M12x16	15.7	25	18	9
A0018304	M14x16	15.7	25	18	9
A0018567	M14x18	17.7	28	20	10
A0018095	M16x18	17.7	28	20	10



High Tensile T-Nuts (Type TN)					
System Code	d x l	a	e	h	k
A0018568	M16x20	19.7	32	24	12
A0018306	M18x20	19.7	32	24	12
A0018307	M20x22	21.7	35	28	14
A0018573	M20x24	23.7	40	32	16
A0018574	M22x24	23.7	40	32	16
A0018308	M24x28	27.7	44	36	18
A0018578	M24x30	29.7	48	38	19
A0018579	M27x32	31.6	50	40	20
A0018580	M24x36	35.6	54	44	22

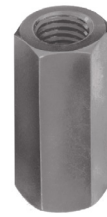

A0018268

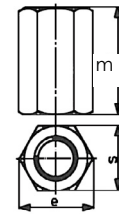

No. 6334. Tensile Strength 1000 N/ mm². For functional and safety purposes, bolts and/or studs to be coupled should be screwed in, on either side to half the length of the nut. The maximum screw in length 1 x Ø.

High Tensile Extension Nuts (Type EN)				
System Code	d	s	e	m 3d
A0018268	M6	10	11.5	18
A0018269	M8	13	15.0	24
A0018255	M10	16	17.8	30
A0018256	M12	18	20.0	36
A0018257	M14	21	23.4	42
A0018258	M16	24	27.7	48
A0018259	M18	27	31.2	54
A0018260	M20	30	34.6	60
A0018261	M22	34	37.7	66
A0018262	M24	36	41.6	72



A0018284

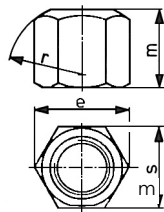

DIN 6330B. Tensile Strength - 1000 N/ mm² with spherical end matching taper face of DIN 6319 D or G. Flat end matching hardened washers DIN 6340.

High Tensile Fixture Nuts (Type FN)					
System Code	d	s	e	m 1,5d	r
A0018284	M6	10	11.5	9	9
A0018285	M8	13	15.0	12	12
A0018271	M10	16	18.2	15	15
A0018272	M12	18	20.4	18	17
A0018273	M14	21	23.8	21	20
A0018274	M16	24	27.7	24	22
A0018275	M18	27	31.2	27	24
A0018276	M20	30	34.6	30	27
A0018277	M22	34	38.6	33	30
A0018278	M24	36	41.6	36	32



A0018253

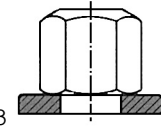

DIN 6340. Tensile Strength - 1200/1400 N/ mm².

Hardened Washers (Type W)				
System Code	For Bolt	Ø d1	Ø d1	s
A0018253	M6	6.4	17	3
A0018254	M8	8.4	23	4
A0018290	M10	10.5	28	4
A0018479	M12	13.0	35	5
A0018245	M14	15.0	40	5
A0002823	M16	17.0	45	6
A0018593	M18	19.0	45	6
A0018247	M20	21.0	50	6
A0018595	M22	23.0	50	8
A0018248	M24	25.0	60	8



A0018242

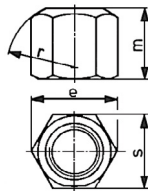

DIN 633. Tensile Strength - 1000 N/ mm² (milled).

High Tensile Collar Nuts (Type CN)						
System Code	d	s	e	m 1,5d	a	d1
A0018242	M6	10	11.5	9	3.0	14
A0018243	M8	13	15.0	12	3.5	18
A0018229	M10	16	18.2	15	4.0	22
A0018230	M12	18	20.4	18	4.0	25
A0018231	M14	21	23.8	21	4.5	28
A0018232	M16	24	27.7	24	5.0	31
A0018233	M18	27	31.2	27	5.0	34
A0018234	M20	30	34.6	30	6.0	37
A0018235	M22	34	38.6	33	6.0	40
A0018236	M24	36	41.6	36	6.0	45



A0018639

All elements heat treated & blackened.

Standard Clamping Kits (Type SCK)						
System Code	R Slot Width	Studs	T Nuts	Coupling Nuts	Step Clamps	Step Blocks
	mm					
A0018639	12	4 off M10x75, 100, 125, 150, 175, 200	6 off M10	4 off M10	6 off	6 pairs



Standard Clamping Kits (Type SCK)						
System Code	T-Slot Width	Studs	T Nuts	Coupling Nuts	Step	Step Blocks
	mm					
A0018640	14	4 x M12 x 75, 100, 125, 150, 175, 200	6 x M12	4 x M12	6	6 Pairs
A0018604	16	4 M14 x 75, 100, 125, 150, 175, 200	6 x M14	4 x M14	6	6 Pairs
A0018641	18	4 M16 x 80, 100, 125, 150, 200	6 x M14	4 x M16	6	6 Pairs



CP150TPAK2-15

Coolant Pumps (TPAK2)					
System Code	Flange to Impeller Length	Power	Pump Volume	Head	Voltage
	mm	kW	l/mm		
CP150TPAK2-15	150	0.75/1.0	45/70	4.5/6	220/380
CP180TPAK2-18	180	0.75/1.0	45/70	4.5/6	220/380
CP250TPAK2-25	250	0.75/1.0	45/70	4.5/6	220/380
CP150TPAK4-15	150	0.95/1.2	125/160	8/10	220/380
CP180TPAK4-18	180	0.95/1.2	125/160	8/10	220/380
CP250TPAK4-25	250	0.95/1.2	125/160	8/10	220/380
CP150TPAK8-18	150	1.6/1.8	200/250	10.2/12	220/380
CP180TPAK8-18	180	1.6/1.8	200/250	10.2/12	220/380
CP250TPAK8-18	250	1.6/1.8	200/250	10.2/12	220/380



CP9009/220

Coolant Pumps					
System Code	Length from Flange to Impeller	Power	Pump Volume	Head	Voltage
	mm	kW	l/mm		V
CP9009/220	90	0.09	35	2	220
A0010817	120	0.09	35	2	220
CP17009/220	170	0.09	35	2	220
CP22009/220	220	0.09	35	2	220
G0011177	90	0.09	35	2	380
A0031640	120	0.09	35	2	380
A0031641	170	0.09	35	2	380
G0011176	220	0.09	35	2	380
G0011228	120	0.15	75	2	380
A0031642	170	0.15	75	2	380
G0010818	220	0.15	75	2	380
G0010819	270	0.15	75	2	380
CP35015/380	350	0.15	75	2	380
A0039326	270	0.37	150	4	380
A0010820	270	0.55	180	4	380
G0010822	350	0.55	180	4	380
CP12009/500	120	0.09	35	2	500
CP17009/500	170	0.09	35	2	500
CP17015/500	170	0.15	75	2	500



00B

Rubber or Polyurethane Base. The rubber base has a hardness of 65 shore. The Polyurethane base can withstand higher loads and is resistant to chemicals and oils.

Machine Mounts					
System Code	Base Type	Working Range	Base Ø	Base Height	Spigot
		Kg			V
00B	Rubber	30-100	60	18	M10
0B	Rubber	80-150	70	22	M12
1B	Rubber	100-350	90	25	M12
2B	Rubber	300-600	115	29	M16
3B	Rubber	500-900	125	31	M16
4B	Rubber	800-1500	150	33	M16
F - 90	Polyurethane	500-2000	100	30	M16
F - 120	Polyurethane	2000-4000	120	33	M20
F - 160	Polyurethane	4000-6000	180	40	M20



The Original Modular Hose System



Max. Pressure: 3600 PSI

Coolant Hose Assemblies, Fittings & Units - 6.35 mm System		
System Code	Image	Description
A0031915		Hose Assembly Kit 6.35 mm x 300 mm Long
G0001587		6.35 mm Hose Segments 290 mm Long
G0001588		1.6 mm Round Nozzle
G0001615		3 mm Round Nozzle
G0001589		6 mm Round Nozzle
G0001616		1/8" NPT Male Connector
G0001617		1/4" NPT Male Connector
G0001618		25 mm Flare Nozzle
G0001619		Y Fitting
G0001620		Double Socket
G0001621		6.35 mm to 1/8" NPT (Female) Socket
G0001622		3/8" NPS (Female) Adaptor
G0001623		1/4" NPS (Female) Adaptor
G0001624		Elbow Fitting
G0001625		T-Fitting
G0001626		1/8" BSPT Male Connector

Coolant Hose Assemblies, Fittings and Units - 6.35 mm System		
System Code	Image	Description
G0001627		1/4" BSPT Male Connector
G0001628		1.6 mm 90° Nozzle
G0001629		3 mm 90° Nozzle
G0001630		6 mm 90° Nozzle
A0031886		6 mm 90° Spray Bar Nozzle
G0001631		Extended Element with Clamp - Pack of Four
G0001632		Extended Element
G0001633		Clamp
G0001634		Side Flow Nozzle
G0001635		Circular Flow Nozzle Kit
G0001636		End Cap
G0001637		Swivel Nozzle 1 mm ø Holes
G0001638		Swivel Nozzle 1.5 mm ø Holes
G0001649		Hose Segments 1000 mm Long
G0001596		In Line Check Valve
G0001597		1/4" NPT Male Valve
G0001598		1/4" NPT Female Valve
G0001599		In Line Valve
G0001600		Manifold Bracket
78001		Hose Assembly Pliers

Coolant Hose Assemblies, Fittings & Units - 12.7 mm System

System Code	Image	Description
A0031919		Hose Assembly Kit 12.7 mm ø x 330 mm Long
A0031920		12.7 mm ø Segments 300 mm Long
G0001688		10 mm ø Round Nozzle
G0001689		12 mm ø Round Nozzle
G0001590		3/8" NPT Connector
G0001690		1/2" NPT Connector
A0031922		6 mm ø Round Nozzle
A0003507		32 mm Flare Nozzle
A0039277		Y-Fitting
A0003508		63 mm Flare Nozzle
A0008591		Double Socket
A0003512		12.7 mm to 6.35 mm Adaptor
A0003513		Y Reducer 12.7 mm to 6.35 mm
A0008641		3/8" NPS Adaptor
A0008661		Elbow Fitting
G0001697		T Fittings
A0003514		3/8" BSPT Connector
G0001698		1/2" BSPT Connector
G0001698		6 mm 90° Nozzle

Coolant Hose Assemblies, Fittings and Units - 12.7 mm System

System Code	Image	Description
G0001700		10 mm 90° Nozzle
G0001701		12 mm 90° Nozzle
G0001702		90° Spray Bar Nozzle
G0001703		90° Nozzle Kit
G0001704		Extended Element
G0001705		Element Clamp
51835		Extended Elements with Clamp - Pack of Four
G0001706		Side Flow Nozzle
G0001707		Circular Flow Nozzle Kit
G0001708		End Cap
G0001605		In-line Check Valve
G0001585		1/2" NPT Male Valve
G0001586		1/2" NPT Female Valve
A0015670		1/2" NPT In-line Valve
G0001607		Manifold Bracket
G0001715		Hose Segment 1000 mm Long
G0001755		Hose Assembly Pliers

Coolant Hose Assemblies, Fittings and Units - 19 mm System

System Code	Image	Description
G0001594		Hose Assembly Kit 19 mm \varnothing x 350 mm Long
G0001746		19 mm \varnothing Segments 300 mm Long
G0001595		19 mm \varnothing Nozzle
G0001747		16 mm \varnothing Nozzle
G0001748		3/4" NPT Connector
G0001749		75 mm Flare Nozzle
G0001750		19 mm to 12.7 mm Adaptor
G0001751		3/4" BSPT Connector
G0001752		19 mm Y-Fitting
G0001753		9 mm to 12.7 mm Y Reducer

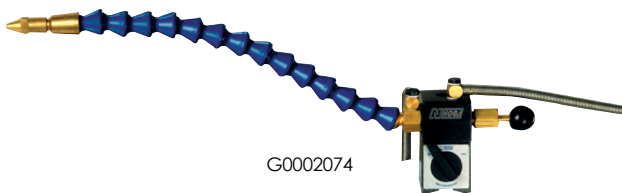

G0002074

Atomises Liquid Coolant for Maximum Heat Dissipation

Mini Cool Mist Spray System	
System Code	Description
G0002074	Strong magnetic base. Separate on/off air & fluid controls Stainless Steel armoured syphon & air hose.



A0017561

Diamond Needle Files

System Code	Shape	Cut	Length
		mm	mm
A00017561	Flat	Medium	140
A00017274	Half Round	Medium	140
A00017276	Round	Medium	140
A00017277	Square	Medium	140
A00017279	Triangular	Medium	140
A00017271	Flat	Fine	140
A00017273	Half Round	Fine	140
A00017275	Round	Fine	140
A00017277	Square	Fine	140
A00017278	Triangular	Fine	140

Diamond Needle Files (Sets)

System Code	Cut	Length
	mm	mm
A0017272	Fine	140
A0017270	Coarse	140



A0017285

Diamond Hand Laps

System Code	Cut	Length
	mm	mm
A0017285	Medium	140
A0017284	Fine	140



A0016651

Diamond Pastes

System Code	Grain Size	Colour	Approximate Surface Finish Achievable Ra
	μ m		
A0016651	0-1	Light Yellow	0.020-0.040
A0016655	2-3	Yellow	0.020-0.040
A0016656	3-5	Light Green	0.020-0.040
A0016657	5-7	Green	0.032-0.063
A0016658	7-10	Dark Green	0.032-0.063
A0016652	10-14	Light Blue	0.063-0.100
A0016509	14-20	Blue	0.063-0.100
A0016654	20-28	Dark Blue	0.080-0.160
A0016656	28-40	Red	0.080-0.160



A0016501

Square Sharpening Stones		
System Code	Size	Grade
	mm	
A0016501	100 x 10	A220
A0016502	100 x 10	A600
A0016503	150 x 13	A220
A0016504	150 x 13	A600
A0016505	150 x 20	A220
A0016506	150 x 25	A220



A0016507

Triangular Sharpening Stones		
System Code	Size	Grade
	mm	
A0016507	100 x 10	A600
A0016508	150 x 13	A220



A0016526

Combination Sharpening Stones		
Stock Code	Size	Grade
	mm	
A0016526	200 x 50 x 25	C120/220M

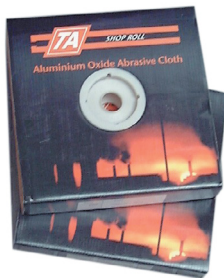

A0017077

Aluminium Oxide Coated Handy Rolls			
System Code	Width	Length	Grit
	mm	mm	
A0017077	25	50	P40
A0017079	25	50	P50
A0017059	25	50	P60
A0017060	25	50	P80
A0017074	25	50	P100
A0017057	25	50	P120
A0017075	25	50	P150
A0017058	25	50	P180
A0017076	25	50	P240

Aluminium Oxide Coated Handy Rolls			
System Code	Width	Length	Grit
	mm	mm	
A0017078	25	50	P400
A0017085	40	50	P40
A0017087	40	50	P50
A0017088	40	50	P60
A0017089	40	50	P80
A0017080	40	50	P100
A0017081	40	50	P120
A0017082	40	50	P180
A0017083	40	50	P240
A0017084	40	50	P320
A0017065	50	50	P40
A0017093	50	50	P50
A0001421	50	50	P60
A0017067	50	50	P80
A0017061	50	50	P100
A0017062	50	50	P120
HR50P150	50	50	P150
A0008090	50	50	P180
A0008091	50	50	P240
A0017091	50	50	P320
A0017092	50	50	P400

Applications:

- High & Low Carbon Steel
- Hard Facing Alloys
- Ductile Iron
- Cast Iron
- Rail Track
- Steel Section, Bar & Tube
- Weld Blending
- Plastics
- Fiberglass
- Carbon Fiber

**DIAMOND X
Diamond X Wheels**



Crimped Steel Wire Used for Surface Cleaning After Welding and other Applications



A0017097

Circular Wire Wheels						
System Code	∅	Face Width	Bore	Wire ∅	Wire Length	Max. RPM
	mm	mm	mm	mm	mm	
A0017097	100	19	20	0.3	17	6000
A0016522	150	25	32	0.3	30	6000
A0017098	200	25	32	0.3	45	4500
A0016523	250	25	32	0.3	50	3600

MACHINE TOOLING

Standard



Heavy-Duty

A0017100

A0018042

Crimped Steel Wire. Used for the Removal of Paint, Rust & Corrosion

Wire Wheels with Shank					
System Code	Ø	Width	Shank Ø	Wire Ø	Max. RPM
	mm	mm	mm	mm	
A0017100	38	5	6	0.3	6000
A0017101	50	7	6	0.3	4500
A0017103	75	10	6	0.3	4500
A0018047	100	12	6	0.3	4500
A0018042	30	9	6	0.3	6000
A0018043	50	17	6	0.3	4500
A0018044	60	18	6	0.3	4500
A0018045	70	18	6	0.3	4500
A0018046	80	19	6	0.3	4500



A0016482

Crimped Steel Wire. Cleaning Prior to and after Welding. Removal of Spatter and Corrosion. Used on Angle Grinders.

Wire Cup Wheels					
System Code	Ø	Bore	Pitch	Wire Ø	Max. RPM
	mm	mm	mm	mm	
A0016482	100	M14	2	0.3	8500
A0016489	150	M14	2	0.3	6500



A0016482

Heavy-Duty Cleaning on Large Metal Surfaces and Weld Scale Removal.

Knotted Wire Cup Wheels					
System Code	Ø	Bore	Pitch	Wire Ø	Max. RPM
	mm	mm	mm	mm	
A0016482	100	M14	2	0.5	8500
A0016483	120	M14	2	0.5	6500



A0018037

Large Trimming Area with Polishing Effect. For use with Angle Grinders.

Double Row Knotted Wire Cup Wheels					
System Code	Ø	Bore	Pitch	Wire Ø	Max. RPM
	mm		mm	mm	
A0018037	100	M14	2	0.5	8500
A0018038	125	M14	2	0.5	6500
A0018039	150	M14	2	0.5	6500



A00116490

Used for the Removal of Rust Corrosion & Paint.

Wire Wheels with Shank				
System Code	Ø	Shank Ø	Wire Ø	Max. RPM
	mm	mm	mm	
A0016490	30	6	0.2	4500
A0018032	50	6	0.3	4500
A0018033	63	6	0.3	4500
A0018034	75	6	0.3	4500

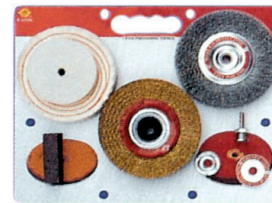

A0017104

Circular wheels with separate shanks.

Sets of Wire Wheels			
System Code	No. of Wheels	Wheels Ø	Shank Ø
		mm	mm
A0017104	3	25, 28, 50	6
A0017105	3	50, 63, 75	6
A0017105	5	25, 38, 50, 63, 75	6



A0017108

With Shanks.

Sets of Cup Wheels					
System Code	No. of Wheels	Wheels Ø	Cup Wheel Ø	End Wheel Ø	Shank Ø
		mm	mm	mm	mm
A0017108	2	50, 75	-	-	6
A0017110	6	38, 50, 63, 75	50	-	6
A0017107	2	100	50	-	6
A0017109	4	50, 75	50	25	6